

B81.81

A professional range of machines designed for smaller, lightweight tractors. Requiring only a mass of 4900kg for the tractor, this range of arm mowers really gives the contractor true flexibility.

The 3 arm arrangement gives a versatile reach characteristic, allowing cutting over obstacles such as fences and guard rails.

Key Features

- 8.1m reach
- 1.2m or 1.5m cutting heads
- Oil cooled as standard
- ICS fully proportional controls



Want to know more about the B81.81?

Scan the QR code to the left with a smart phone or tablet and compatible app to instantly view the page.

Alternatively visit: <http://www.bomford-turner.com/landscape/arm-mowers/b8181/>



Heavy duty twin ram slew system

Includes hydraulic breakout to protect machine operator.



Telescopic arm

Gives increased flexibility.



ICS Controls

Fingertip control with adjustable speed settings.

Product Specification

● Standard ○ Optional — Not Available

B81.81	8.1m T (26'7")
Tractor requirements	
Minimum horse power	140hp
Minimum weight	5200kg 11464lbs
Base unit mounting options	
Front mount	○
Mid-mount	—
Rear mount	●
Three point linkage (CAT II)	—
Axle bracket	●
Overall machine parameters	
Machine weight with head and oil	2490kg 5490lbs
Capacity of oil tank	250L 66USG
Weight of machine with oil but without head	1955kg 4310lbs
Controls	
Cable Control (CC)	○
Low pressure hydraulics (LPH)	—
Electronic proportional control (EPP)	○
Intelligent control system (ICS)	●
Cable rotor reverse	●
Electronic rotor reverse	○
Hydraulic system	
System capability	74hp
Pump flow rate	125L 33USG
Pump type (Gear/Piston/Helical)	Gear
Pump arrangement (Twin/In-line)	Twin
Independent hydraulics	●
Oil cooler	●

B81.81	8.1m T (26'7")
Arm features and main frame	
Forward arm	—
Telescopic arm	●
Telescopic arm stroke	1450mm 4'9"
Power slew	●
Power slew angle	180°
Gravity breakout protection	—
Hydraulic breakout protection	●
Arm float - manual operation	—
Arm float - electronic operation	●
Head float - manual operation	○
Head float - electronic operation	●
Left hand cutting	○
Right hand cutting	○
Left and right hand cutting	●
Arm attachments available	
Variable track bracket (VTB)	○
Sheartrim cutter bar	○
Pro-Saw	○
Ditch cleaner	○
Rotary head	○
Accessories	
Road Lights	—
Debris Blower	—
Warning Arrow (Magnetic / Fixed)	○
Cab Guard Kit	●
Cutting heads (For Flail compatibility see page 95)	
1.2m Pro-Cut - 115/150mm roller	○
1.5m Pro-Cut - 115/150mm roller	○
1.2m Pro-Cut ISMP - 115/150mm roller	○
2m HD head	○

Working Reach

Head used for calcs: 1.2 Pro-Cut

	B81.81 8.1m T (26'7")
A	8.08m / 26'6"
B	7.93m / 26'
C	6.27m / 20'7"
D	6.52m / 21'5"
E	8.92m / 29'3"
X	1.3m / 4'1"
Y	1.0m / 3'3"

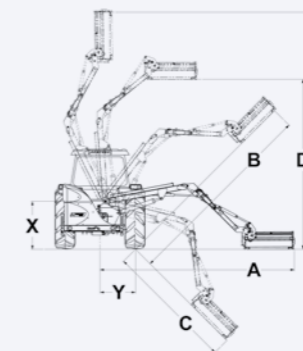

Transport cradle
For fast road transit.