



CREATING A CLEANER, SAFER, HEALTHIER WORLD.

EQUIPMENT



500ze

THE FIRST IN A NEW GENERATION OF
ELECTRIC SWEEPERS

- Sweep an entire 8-hour non-stop shift (Tüv Rheinland tested) with the Tennant Green Machines® 500ze using innovative Lithium-ion technology
- The absence of CO₂ or engine emissions and the low noise make the 500ze perfect for operation in enclosed or crowded pedestrian areas
- Cloudmaker® dust control technology provides exceptional dust control, while using up to 70% less water than traditional street sweepers



THE IMPRESSIVE SUCTION & SWEEPING PERFORMANCE OF THE 500ZE IS EQUAL TO A COMPACT SWEEPER ON THE MARKET.



ZERO EMISSIONS

The 500ze emits no carbon or exhaust emissions creating cleaner cities and cleaner air for pedestrians. The battery-powered street sweeper saves up to 78 tonnes of carbon dioxide over five years. This allows the 500ze to provide a vital step in assisting cities to meet their carbon emission targets.

VIRTUALLY SILENT IN TRANSIT

Operate the 500ze with confidence in early morning or late at night and in noise sensitive areas such as parks, schools, hospitals, residential areas. In transit mode it is difficult to hear the 500ze over the gentle rustling of trees!

INNOVATIVE POWER

The 500ze is powered by dual Lithium-ion battery packs. Its onboard management system intelligently monitors and balances energy levels to achieve maximum performance. Recharging can be completed in 4 hours, and the innovative design allows battery packs to be quickly exchanged if required.

RELIABLE AND LOW RUNNING COSTS

The power and efficiency of Lithium-ion technology make battery power supply as reliable as conventional fuel. The 500ze has real-time battery charge display, low battery alarm and intelligent charge monitoring.

VERSATILE AND COMPACT

Innovative design providing a 0.75m³ capacity hopper, a 1900mm sweeping path, a 2.05m turning circle, 2m clearance height, independent joystick-controlled brushes, no exhaust fumes and low vehicle weight means the 500ze can go almost anywhere.

INSIDE THE

500ze

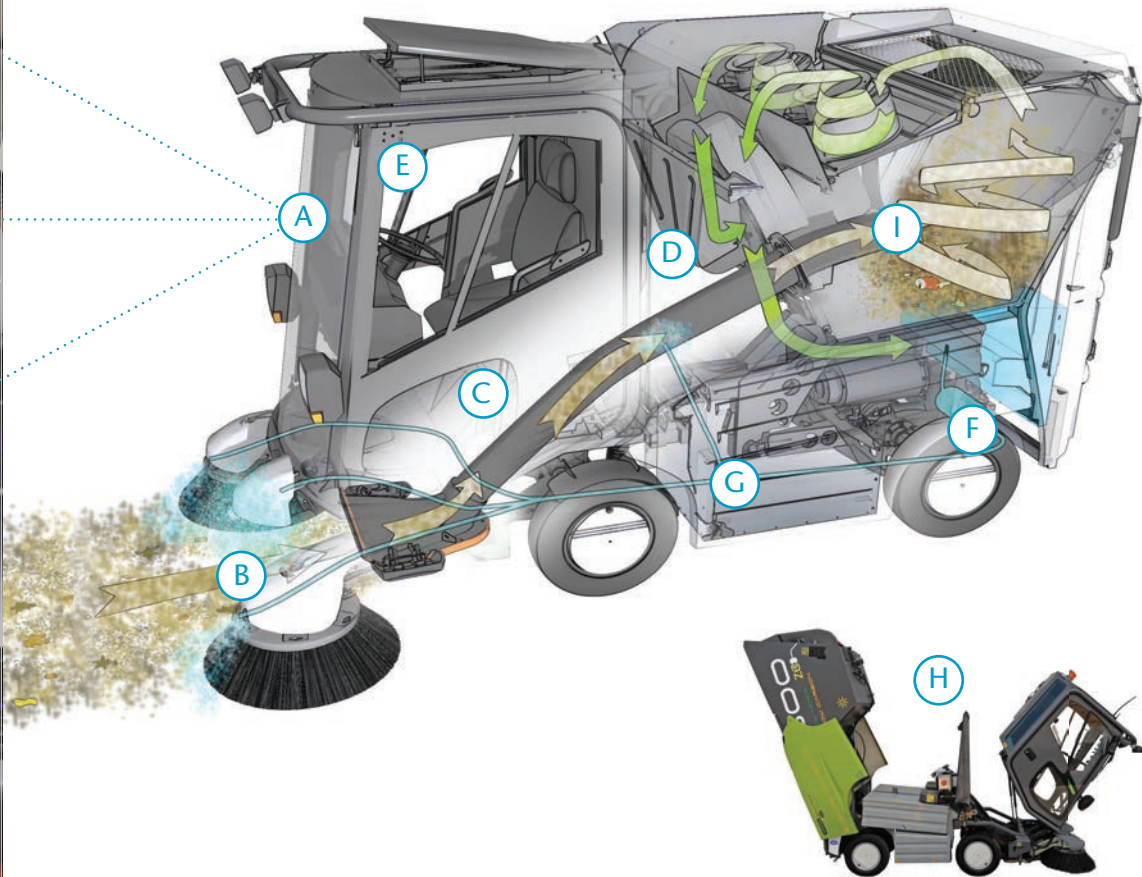

- A** Increase safety with all round visibility.
- B** Sweep around obstacles with independently operated dual brushes for detailed cleaning wherever needed. Brushes adjust to a 1.9 metre cleaning path for maximum sweeping effectiveness.
- C** Improve productivity with one-touch intelligent switching between sweep and transit modes.
- D** Rely on the 500ze vacuum sweeper's durable, best-in-class construction to meet the toughest sweeping tasks.
- E** The advanced vehicle management system provides simplified operation and troubleshooting with built in monitoring, logging and diagnostic features. Ergonomic design cabin and control panel provide class-leading operator comfort.

- F** Experience increased operator comfort and ride with 4 wheel automotive type suspension system.
- G** Twin Lithium-ion battery packs provide up to 8 hours of full sweeping performance.
- H** Make routine maintenance and service quick and easy with complete access to all major systems.
- I** The maintenance-free twin cyclones create a cyclonic action that spins virtually all of the remaining dust out of the airflow before the air is discharged from the rear of the machine. The remaining dust falls down in the hopper.

GENUINE TENNANT PARTS, SUPPLIES AND SERVICE

Tennant Service Offering

- Maximise safety, productivity and uptime
- Control and protect your investment and lower your total cost of ownership
- Benefit from over 200 factory-trained service technicians across Europe

Tennant Parts & Supplies

- Operate your machine with confidence
- Benefit from years of worry-free operation

Tennant Cleaning Solutions

- Further your sustainable cleaning goals
- Choose sustainable benefits your company wants



Certified by ISO9001

500ze MACHINE SPECIFICATIONS*

SWEEPING SYSTEM

Type	Vacuum sweeper
Cleaning path: minimum (brushes in)	1,300 mm
Maximum (brushes fully extended)	1,900 mm
Hopper volume capacity	0,75 m ³

DUST CONTROL SYSTEM

Dust filtration separation	Three -stage filtration
Stage 1	Side entry cyclone swirl plate
Stage 2	Stainless steel filter screen
Stage 3	Twin cyclones
Dust suppression system	Standard
CloudMaker™	
Vacuum impeller	10 blade alloy steel

PROPELLING SYSTEM

Drive motor	15kW (max) Induction AC traction motor
Suspension: front & rear	automotive type coil over-shock suspension
Travel speed	up to 25 km/h
Sweeping speed	0-12 km/h

MACHINE DIMENSIONS

Length	3,330 mm
Width	1,200 mm
Height	1,980 mm
Weight	
Kerb Weight	2,300 kg
GVW	2,670 kg
Wheel base	1,400 mm
Turning radius dimensions	
Kerb-to-kerb	2,750 mm
Wall-to-wall	3,550mm

OPTIONS

Air conditioning
Color CCTV reverse camera
Pressure washer
Central greasing
Wander Hose
Radio/CD/Bluetooth
Customised colour

WARRANTY

For warranty conditions please contact your local Tennant representative.

* specifications subject to change



SEEING IS BELIEVING

For a demonstration or additional information contact us:

TENNANT UK CLEANING SOLUTIONS LTD

Gladstone Road
Northampton NN5 7RX
UNITED KINGDOM
Tel: 0800 111 4402 (local rate UK only)
Tel: 01604 583191
Fax: 0845 052 9349
Email: sales.uk@tennantco.com
Email: enquiries@tennantco.com

TENNANT CEE GmbH

Sommerfeld 1
5202 Neumarkt am Wallersee
AUSTRIA
Tel: +43 (0)6216 4524 & 4525
Fax: +43 (0)6216 4524 20
E-mail: office@tennant-cee.com

TENNANT EUROPE NV

Plantin & Moretuslei 220
2018 Antwerp
BELGIUM
Tel: +32 3 217 94 11
Fax: +32 3 217 94 19
E-mail: europe@tennantco.com