



**FERRARI**

MADE IN ITALY

# COBRAMI





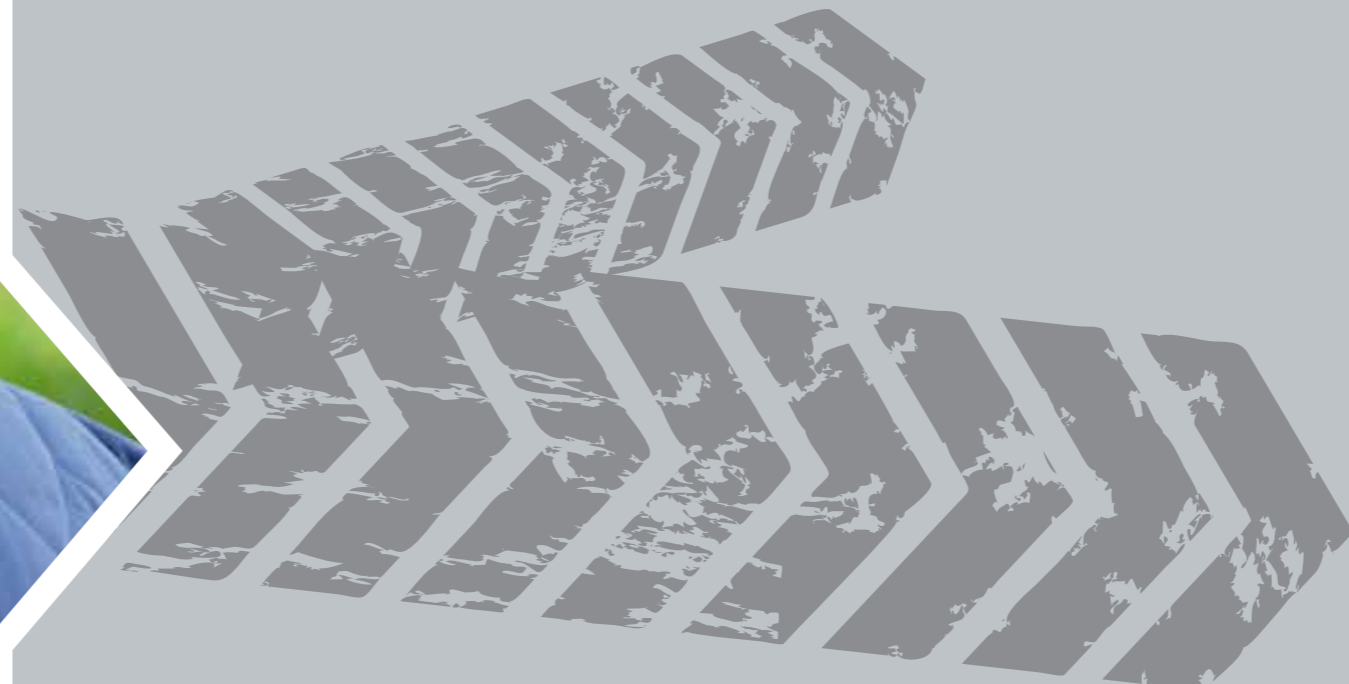

# COMMITMENT GENERATES TRUST

A project created by a team of competent and determined people. Hundreds of hours of work dedicated to research and development activities entirely for the production of a range of specialized medium-power tractors with unique features.

The goal was shared by all of us at **FERRARI** and was completed with the commitment and professionalism that has always made us stand out.

**COBRAM V65** tractors are the result of all this: high quality machines, extremely versatile and reliable, manufactured with attention to even the smallest details. These tractors are guaranteed by a great brand name and a professional distribution network in over 100 countries all over the world.

With the **COBRAM** series, **FERRARI** has strengthened its position of prestige in the sector.





# NEW CONCEPTION MACHINERY

Seeking for maximum efficiency has been the focal point of developing the **COBRAM series**. This is how concrete tractors were built, with attention to the smallest details, with generous and staid engines supported by solid and compact transmissions for optimal weight distribution on the axles.

Particular attention was given to volumes to minimize the overall dimensions, the most compact of its category, without affecting the mechanical efficiency, comfort and durability.



## STRONGER AND MORE PROFITABLE THAN EVER

Like all the products that boast the FERRARI trademark, also the new **COBRAM range** has been designed to offer concrete value to the investment: lower consumption, greater performance, higher versatility and reliability. The inspiring principle of the project was to create tractors giving the most favourable working conditions and offering their owners more competitive financial management.

### A RELIABLE COMPANY

With over sixty years of experience to their name, high quality production, remarkable design, production and distribution capability, **FERRARI** is one of the most established companies in the agricultural machinery sector and has been ISO 9001 certified since 1994.

### AN EXPERT NETWORK

Competence and experience make every **FERRARI** dealer stand out: professionalism you can rely on, the certainty of being advised and accompanied through the choice of machine that is right for your specific needs.



### QUALITY SERVICES

Before and after sales, the quality of their services can make the difference. Choosing a FERRARI tractor means:

- **AFTER-SALES SUPPORT:** the integrated network of authorised dealers and spare parts dealers is at hand for anyone seeking rapid and safe assistance.



- **GUARANTEE:** FERRARI provides a two-year guarantee on all COBRAM tractors, included in the price, also covering the engine.



### COBRAM V65 AR

**Isodiametric, monodirectional or reversible, with central articulation**

It is the reference version in the field of specialized tractors and is subject to the standards established according to the type of use for which they were conceived and, above all, to be compatible with the environment in which they will operate. Its compact size, the performance of the hydraulic system, and the small turning radius make **COBRAM V65 AR** tractors extremely versatile to perform all the tasks for which they were designed: crops in rows, processing in greenhouses, greens maintenance of parks and municipalities. All this brings out the great character of these machines and makes them irreplaceable for use in tight spaces.



### COBRAM V65 RS

**Isodiametric, monodirectional or reversible, with steering wheels**

This is the most used version among the specialized tractors, the one offering the largest number of applications. Performance and comfort make these machines high performers for winegrowing and vegetable cultivations. They are also ideal for the greens maintenance both in Summer and Winter. Remarkable stability, even on sloping areas, compact overall dimensions, excellent manoeuvrability and proper weight distribution on the axles while working, are features that enhance the value of **COBRAM V65 RS** tractors, making them unrivalled equipments for the purposes which they were designed for.



## COBRAM

### THE BENEFITS

- **HIGH POWER and LOW FUEL CONSUMPTION** thanks to the use of high efficiency engines with great operation economy.
- **OS-FRAME TRANSMISSIONS** to ensure maximum stability and mechanical efficiency, even on uneven terrain.
- **PERFECT WEIGHT DISTRIBUTION** on the axles, so as to optimize the performance and traction of the vehicle in the working position.
- **LOW CENTRE of GRAVITY** to ensure maximum stability on the slopes without penalising the ground clearance.
- **REVERSIBLE DRIVE**, available as an option on all models
- **HIGH FLOW RATE OF OIL** to the distributors to allow the use of different pieces of equipment combined in order to curb processing costs and time.
- **ELECTRONIC JOY-STICK** available as an option on all models.
- **SMALL WHEEL-BASE** only 139 cm so the machine can easily move in any type of crop field and on every type of soil.
- **COMFORT** for the protection and respect of "our most valuable asset": the driver



# ENGINES: POWER, PERFORMANCE AND ECONOMY



For the model D753 TE3, VM has developed the new EGR System located inside the engine. The system recycles the exhaust gases that, properly blended, return to the combustion chamber, thereby drastically reducing the emissions of nitrogen oxides (NOx) and fuel consumption.



THE CHOICE TO USE A **MAXIMUM OF 2600 RPM** WAS DESIGNED TO REDUCE POWER CONSUMPTION, NOISE AND VIBRATION TO THE BENEFIT OF ECONOMY MANAGEMENT AND COMFORT. HOWEVER, THE POWERS THAT COUNT ARE NOT ALTERED: ALL THE ENGINES REACH PEAK TORQUE BETWEEN 1950 AND 2100 RPM.



HIGH **POWER**

HIGHEST **RELIABILITY**

**STEADINESS**

COMPACT **SIZE**

LOW **VIBRATION**-LEVEL

The roads to travel are always uphill, the jobs to be done are always on a tight deadline, the crops cannot be subordinate to the needs of your vehicle. That's why you need the most out of the performance levels provided by the **VM D753 engines** supplied with the **COBRAM series**: engines that are winning and will always allow you to hit your mark because they are built with the understanding that the activities of our Customers depend on the efficiency, reliability and economy of their equipment.

The VM engine available for the COBRAM V65 is a Turbo diesel with three inline cylinders of 2.2 litres, developing 56 hp at 2600 rpm.

COBRAM	Type	Power (kW/hp)	No. of Cylinders	Displacement	Aspiration	Cooling
V65	VM D753 TE3	41,2 / 56	3	2230	Turbo	Liquid



## THE CHARACTERISTICS:

- **TUNNEL BORE BASE** which allows a great flexural and torsion rigidity.
- **ROTARY MECHANICAL INJECTION PUMPS** that make these propellers perform in every condition of use, increasing reliability and lifespan.
- **GEAR DISTRIBUTION WITH FORCED LUBRICATION**, the maximum that you can ask for from a diesel.
- **HYDRAULIC TAPPETS** to minimise noise and eliminate maintenance.
- **LOW-INERTIA TURBOCHARGERS** for an immediate response when it demands power.



# AN ABSOLUTELY UNIQUE CONTEXT



## OS-FRAME

### CHASSIS AND TRANSMISSION

The chassis of the tractor is fitted out with **OS-Frame transmissions** that, with a sole shaft and a sole central joint, guarantee maximum mechanical output. It is a "monolithic" structure in a single cast iron casting. The joint in the middle of the machine lets the front axle oscillate by up to 15° with respect to the rear axle, stabilising the trim on slopes to guarantee maximum stability and safety, as well as constant traction on all types of terrain.

The same transmission allows you to have a particularly **low centre of gravity**, without sacrificing any ground clearance. Such characteristics are essential for the uses which these vehicles are intended.

### GEARBOX: always the right gear ratio

The gearbox is synchronized with 24 speeds with a synchro reverser which can be engaged while the engine is running. The gears have a helical profile to obtain the maximum manoeuvrability with gentle and progressive clutches. **Designed without overlapping speeds** in three ranges so you can always find the right gear ratio for each type of work.

### Superior quality AXLES

The choice of using only axles with **planetary reduction gears** was determined by the need to minimize the pitch of the machine in order to increase its manoeuvrability, enhance its prestige and, most important, its reliability.

**Graph of speeds in km/h of the AR and RS version tractor**  
The graph highlights the progression of the gear ratios without any overlap of speed in any forwarding range.



### BRAKES that always rise to the occasion

**Multi-discs brakes in oil bath** of latest generation ensure safe braking. The parking brake is designed with a practical and ergonomic grip for easy use even when the operator is seated for reverse drive.

### PTO: effective and efficient

The rear PTO with **electro-hydraulic control** and progressive clutch runs at 540/750 rpm, is independent from the gearbox and synchronized with all the travel speeds. It can be engaged under load, it has the brake in the released position and the safety mechanism that prevents accidental engagement.

### TRACTION 4WD

The **4-wheel drive** allows to work safely on every type of soil, by maximizing the traction and safety features designed especially for COBRAM tractors.

### A CLUTCH with plenty of added value

The **LONG-LIFE clutch** of the transmission has **multi-discs in oil bath**, without need for adjustment or maintenance. Modular and progressive, it is introduced into the transmission to reduce the overhang of the engine and consequently the length of the unit.





# NEW SOLUTIONS FOR THE DRIVER



The **driving position** of COBRAM tractors one of the best in its category: it combines comfort, ergonomics, functionality and safety in an absolutely original way.

The driving position, **monodirectional or reversible**, was tailored to the driver: the drive module, with **platform suspended on a silent block**, ensures maximum comfort. The **reversibility** is also safe and practical, and can be done in a few seconds.

The **digital display** is integrated in the instrument panel with its non-glare screen. It includes the reading of engine rpm, travel speed and rotation speed of the PTO.

On the **instrument panel**, having a refined design, all the functions are grouped in an optimal manner to allow you to control the conditions of the vehicle.



## FERRARI CABS: THE BEST OF THE BEST

When the cabs of the COBRAM were designed, it was decided to bring our expectations higher than anyone else had previously done.

The cabs were very carefully designed to ensure maximum comfort and pleasant liveability inside. The suspension is fully independent from the tractor chassis. The visibility is provided by large windows, a door on the roof and a four-post frame that allows large glass doors. The structure itself is designed to enable its use in crop rows placed in extremely tight rows with luxuriant vegetation.

They are available in the **Luxus** and **Comfort** versions, the latter equipped with air conditioning system located inside the roof frame in order not to increase the height of the machine.





# HYDRAULIC SYSTEM: IT HAS NEVER BEEN SO EFFICIENT



## THE FORCE OF THE LEVERS

The **rear lifts** are sturdy and reliable, with a "third point" and normal or rapid connectors. Practical and versatile, well suited to all equipment on the market. They are supported by a high performing hydraulic system and, on request, can be supported by a draft and position control.



The hydraulic system consists of a double circuit with two independent pumps: one of 24,8 l/min dedicated to the lift and distributors, the other of 18,9 l/min dedicated to the hydroguide and electro-hydraulic control. As optional a 37,2 l/min oversize pump with heat stabilizer is available.

Hydraulic operating pressure is 180 bar.

## THE DISTRIBUTORS

The hydraulic control valves, in the rear side of the tractor, allow you to use equipments absorbing a large hydraulic flow rate, widely used for crops in rows.

To operate the hydraulic system and the lift by a single device, the COBRAM tractors can be fitted with an **electronically controlled joy stick** to make every manoeuvre involving the hydraulic system of the tractor precise and practical. The Joy-Stick is always accompanied by the increased pump and heat exchanger.



## THE STEERING

One of the features of compact tractors for specialized agriculture is the degree of manoeuvrability of the units: the **power-assisted steering** of COBRAM tractors, combined with the unique features of the transmission, give these machines excellent performance on bends.





# PREVENTION IS BETTER THAN CURE!



# OTHER GOOD REASONS FOR CHOOSING COBRAM



## THE HEAT DISPOSAL

The heat disposal, both from the engine and the hydraulic system, is essential to enable compact and powerful tractors to perform the demanding jobs for which they are intended without any problems.

For the **COBRAM series** a cooling system is available as optional allowing the engine and the whole hydraulic system to always operate within the maximum safety margin.



## THE AIR IS ALWAYS CLEAN

For applications where there is a strong presence of "particulate", such as mowing the grass or shredding vine-branches, the standard system can be also supported by the **SCS (Self Cleaning System®)** that eliminates the annoying clogging problems of grilles and radiators, avoiding the overheating of engine and hydraulic system.

The system consists of a better performing engine **cooling system**, combined with **two fans** with intermittent/combined operation: a suction fan with electromagnetic control and a compact electric blower fan.

The **Self-Cleaning System®** is programmed by mean of a 3-function button, which respectively activates:

- **SCS** the SCS dual-fan system
- **ECO** the suction fan only with intermittent operation
- **CMF** only the suction fan with constant operation

The operator can select the function according to the different uses and needs



COBRAM tractors are specialized like few others. Built for those who want only the best. The FERRARI original and optional attachments available make them even more unique.

## 1. TYRE RANGE

The width and height, the degree of compaction on the ground, the more or less aggressive 'GRIP' are just some of the aspects that give the wheels of specialized tractors a capital role. We tested and reserved for the COBRAM the best alternatives on the market, so that our customers can always find the right solution for their needs.

## 2. 3-POINT HITCH

To make the implement application on the tractor easier, the rear three-point hitch can be fitted with practical quick couplers which are available in two versions:

- Quick couplers cat. 1 with tie-rods adjustable in length
- L-shaped quick couplers cat. 1 with arms and tie rods adjustable in length and hooks adjustable in width.

## 3. RANGE OF WEIGHTS

For some operations or special loads to be connected to the tractor, a range of weights is available to be mounted on the wheels or on the forepart of the machine next to the engine.

## 4. TOW HOOKS

As for towing, there are three types of hooks: the Cuna hook, the CEE hook and the CEE hook with quick height adjustment.

## 5. HDR HYDRAULIC SUSPENSION

The accumulator for weight compensation HDR is perfect to help you to adjust the pressure on the terrain of the equipment mounted on rear lift of the tractors.





**TECHNICAL FEATURES  
COBRAM AR**



		8.25-16	250/80-18	280/70R18	320/65R18	260/70R20	31x15.50-15 XTC	31x15.50-15 STG	31x13.50-15 Garden
		WITH ADJUSTABLE RIM	WITH ADJUSTABLE RIM	WITH ADJUSTABLE RIM	WITH ADJUSTABLE RIM	WITH ADJUSTABLE RIM	WITH FIXED RIM	WITH FIXED RIM	WITH FIXED RIM
<b>A</b> Tyre width mm.		212	240	282	319	258	368	394	351
<b>B</b> Tyre height mm.		848	879	849	873	872	800	800	782
<b>C</b> Wheel track min/max mm.	Mono	794 - 1100	865 - 1107	869 - 1119	931 - 1119	846 - 1120	1003	1003	1037
	Rev	827 - 1100	865 - 1107	931 - 1119	931 - 1119	902 - 1120			
<b>D</b> Width min/max mm.	Mono	1006 - 1312	1105 - 1347	1151 - 1401	1250 - 1438	1104 - 1378	1371	1397	1388
	Rev	1039 - 1312	1105 - 1347	1213 - 1401	1250 - 1438	1160 - 1378			

**TRACTOR DIMENSIONS (AR VERSION) WITH FRONT FRAME (mm):**

	E	F	G	H	I Min-Max	L Max (mono-rev)	M Min-Max	N Max	O
<b>COBRAM V65 AR</b>	1150	1390	730	3270	207 / 266	2220	675	2106	958

**STEERING RADIUS (AR VERSION) WITH THE FORESEEN WHEELS:**

Type of tyre	8.25-16	250/80 18	280/70 18	320/65 18	260/70 20	31x15.50 15	31x13.50 15
<b>mm</b>	2450	2500	2530	2650	2600	2700	2700

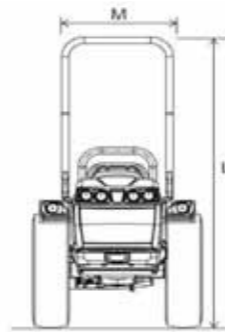
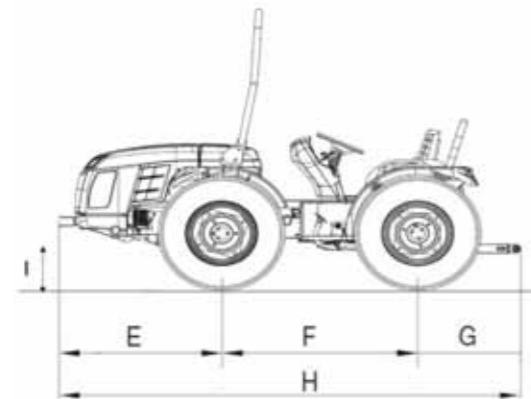
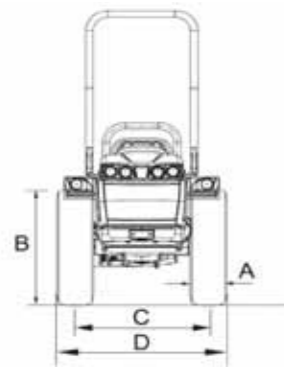

TECHNICAL FEATURES	COBRAM V65 AR
<b>CHASSIS</b>	Swinging integral chassis OS-FRAME with central articulation
<b>DRIVE</b>	Four-wheel drive, permanent
<b>ENGINE</b>	
Manufacturer	VM
Model	D753 TE3
Number of cylinders	3
Displacement cm <sup>3</sup>	2230
Aspiration	Turbo
Emission level	Tier 3
Power KW/HP	41,2 / 56
Nominal speed (rpm)	2600
Maximum torque (Nm/rpm)	185 / 1400
Cooling	Water
Tank capacity (lt.)	45
<b>TRANSMISSION</b>	Synchronized gearbox: 12 forward and 12 reverse speeds with synchronized reverser
Main clutch	Multidisc, in oil bath
<b>DIFFERENTIAL</b>	Front and rear differential lock, electro-hydraulically controlled
<b>AXLES</b>	Front and rear, with epicyclic reduction units
<b>POWER TAKE-OFF</b>	Rear, independent from the gearbox, 540/750 r.p.m. and synchronized with the gearbox
PTO clutch	Multidisc, in oil bath
Engagement control	Electro-hydraulic
<b>HYDRAULIC SYSTEM</b>	Double circuit with independent pumps
Flow rate to the lift and the distributors (lt./min.)	24,8 (optional oversize pump 37,2)
Flow rate to the hydroguide and electro-hydraulic control (lt./min.)	18,9 (optional oversize pump 24,8 and heat exchanger)
Maximum hydraulic pressure (bar)	180
<b>DISTRIBUTORS</b>	Mechanical control to max. 6 hydraulic couplers
Rear (Standard)	1 double acting (Hydraulic lift by rams) 2 double acting (Draft and position control)
Rear (optional)	1 single acting and 1 double acting with float or 2 double acting (Hydraulic lift by rams) 1 single acting and 1 double acting with float instead of the serial ones (Draft and position control)
Joy stick (optional)	Electronic control of distributors composed of: 1 single-acting with adjustable flow and 3 double-acting
<b>ELECTRIC SYSTEM</b>	
Battery (Ah)	70
Alternator (A)	70
<b>REAR LIFT</b>	Standard: by two external rams - Optional: Draft and position control
Three-point hitches	Standard: standard couplers cat. 1 - Optional: quick couplings cat. 1, L-shaped lift arms, lift rods adjustable in length and hooks adjustable in width
Three-point tie bar	With manual adjustment
Lifting capacity at the end of the arms kg	1510
<b>DRIVING UNIT</b>	With half-platform for the monodirectional version - With suspended platform on "silent-block" for the reversible version
Driving platform	Monodirectional or reversible with rotating platform and twin pedal assembly
<b>SEATS with safety belts</b>	Standard: Sprung seat - Optional: 'Bostrom' seat
<b>SERVICE BRAKES</b>	Oil immersed multidisc, acting on the rear transmission
Parking brake	Acting on the service brakes
<b>STEERING</b>	With hydrostatic steering on articulated joint. Flow deviator for steering unit
<b>SAFETY</b>	
Roll-bar frame (standard)	Front, homologated
Cabin (optional)	Sound-proof, mounted on 'Silent block', heating and ventilation systems. Optional: air conditioning
<b>CONSOLE</b>	Digital type with chrono-tacho-gyrometer, water thermometer, control warning lights, reading of rpm, forward speed and rotation speed of power takeoff
<b>TYRES</b>	
Standard	8.25-16
Optional	250/80-18* 280/70R18 * 320/65R18 * 260/70R20 * 31x15.50-15 XTC and STG * 31x13.50-15 Garden
<b>TOW HOOKS</b>	
Standard	Rear CUNA and front tow hook
Optional	Rear rotating or rear adjustable in height (Slider type) tow hooks, both EC approved
<b>WEIGHT OPERATIONAL</b>	
With chassis (kg)	1540
With cabin (kg)	1700
<b>OPTIONAL</b>	Flash light, radiator and air suction grille cleaning system "Self Cleaning System", front weight and weights for wheels



**TECHNICAL FEATURES  
COBRAM RS**



	8.25-16	250/80-18	280/70R18	320/65R18	260/70R20	31x15.50-15 XTC	31x15.50-15 STG	31x13.50-15 Garden
	WITH ADJUSTABLE RIM	WITH ADJUSTABLE RIM	WITH ADJUSTABLE RIM	WITH ADJUSTABLE RIM	WITH ADJUSTABLE RIM	WITH FIXED RIM	WITH FIXED RIM	WITH FIXED RIM
<b>A</b> Tyre width mm.	212	240	282	319	258	368	394	351
<b>B</b> Tyre height mm.	848	879	849	873	872	800	800	782
<b>C</b> Wheel track min/max mm.	999 - 1305	996 - 1312	984 - 1324	1074 - 1324	987 - 1325	1100 - 1208	1100 - 1208	1066 - 1242
<b>D</b> Width min/max mm.	1211 - 1517	1236 - 1552	1266 - 1606	1393 - 1643	1245 - 1583	1468 - 1576	1494 - 1602	1417 - 1593

**TRACTOR DIMENSIONS (RS VERSION) WITH FRONT FRAME (mm):**

	E	F	G	H	I Min-Max	L Max (mono-rev)	M Min-Max	N Max	O
<b>COBRAM V65 RS</b>	1150	1390	730	3270	207 / 266	2220	675	2106	958

**STEERING RADIUS (RS VERSION) WITH THE FORESEEN WHEELS:**

Type of tyre	8.25-16	250/80 18	280/70 18	320/65 18	260/70 20	31x15.50 15	31x13.50 15
<b>mm</b>	2800	2830	2930	2950	3350	3250	3200

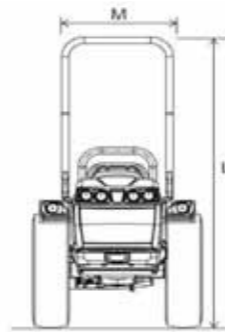
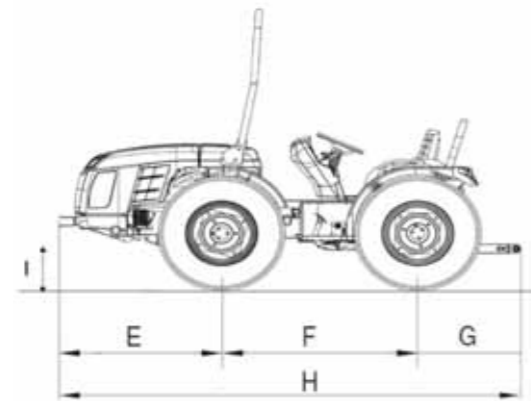
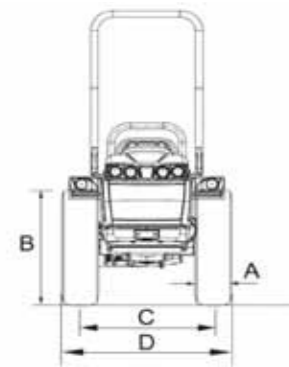

TECHNICAL FEATURES	COBRAM V65 RS
<b>CHASSIS</b>	Swinging integral chassis OS-FRAME with steering wheels
<b>DRIVE</b>	Four-wheel drive, permanent
<b>ENGINE</b>	
Manufacturer	VM
Model	D753 TE3
Number of cylinders	3
Displacement cm <sup>3</sup>	2230
Aspiration	Turbo
Emission level	Tier 3
Power KW/HP	41,2 / 56
Nominal speed (rpm)	2600
Maximum torque (Nm/rpm)	185 / 1400
Cooling	Water
Tank capacity (lt.)	45
<b>TRANSMISSION</b>	Synchronized gearbox: 12 forward and 12 reverse speeds with synchronized reverser
Main clutch	Multidisc, in oil bath
<b>DIFFERENTIAL</b>	Front and rear differential lock, electro-hydraulically controlled
<b>AXLES</b>	Front and rear, with epicyclic reduction units
<b>POWER TAKE-OFF</b>	Rear, independent from the gearbox, 540/750 r.p.m. and synchronized with the gearbox
PTO clutch	Multidisc, in oil bath
Engagement control	Electro-hydraulic
<b>HYDRAULIC SYSTEM</b>	Double circuit with independent pumps
Flow rate to the lift and the distributors (lt./min.)	24,8 (optional oversize pump 37,2)
Flow rate to the hydroguide and electro-hydraulic control (lt./min.)	18,9 (optional oversize pump 24,8 and heat exchanger)
Maximum hydraulic pressure (bar)	180
<b>DISTRIBUTORS</b>	Mechanical control to max. 6 hydraulic couplers
Rear (Standard)	1 double acting (Hydraulic lift by rams) 2 double acting (Draft and position control)
Rear (optional)	1 single acting and 1 double acting with float or 2 double acting (Hydraulic lift by rams) 1 single acting and 1 double acting with float instead of the serial ones (Draft and position control)
Joy stick (optional)	Electronic control of distributors composed of: 1 single-acting with adjustable flow and 3 double-acting
<b>ELECTRIC SYSTEM</b>	
Battery (Ah)	70
Alternator (A)	70
<b>REAR LIFT</b>	Standard: by two external rams - Optional: Draft and position control
Three-point hitches	Standard: standard couplers cat. 1 - Optional: quick couplings cat. 1 and lift rods adjustable in length or quick couplings cat. 1, L-shaped lift arms, lift rods adjustable in length and hooks adjustable in width
Three-point tie bar	With manual adjustment
Lifting capacity at the end of the arms kg	1510
<b>DRIVING UNIT</b>	With half-platform for the monodirectional version - With suspended platform on "silent-block" for the reversible version
Driving platform	Monodirectional or reversible with rotating platform and twin pedal assembly
<b>SEATS with safety belts</b>	Standard: Sprung seat - Optional: 'Bostrom' seat
<b>SERVICE BRAKES</b>	Oil immersed multidisc, acting on the rear transmission, simultaneously or independently
Parking brake	Acting on the service brakes
<b>STEERING</b>	With hydrostatic steering, acting on the front wheels. Flow deviator for steering unit
<b>SAFETY</b>	
Roll-bar frame (standard)	Front, homologated
Cabin (optional)	Sound-proof, mounted on 'Silent block', heating and ventilation systems. Optional: air conditioning
<b>CONSOLE</b>	Digital type with chrono-tacho-gyrometer, water thermometer, control warning lights, reading of rpm, forward speed and rotation speed of power takeoff
<b>TYRES</b>	
Standard	8.25-16
Optional	250/80-18* 280/70R18 * 320/65R18 * 260/70R20 * 31x15.50-15 XTC and STG * 31x13.50-15 Garden
<b>TOW HOOKS</b>	
Standard	Rear CUNA and front tow hook
Optional	Rear rotating or rear adjustable in height (Slider type) tow hooks, both EC approved
<b>WEIGHT OPERATIONAL</b>	
With chassis (kg)	1560
With cabin (kg)	1700
<b>OPTIONAL</b>	Flash light, radiator and air suction grille cleaning system "Self Cleaning System", front weight and weights for wheels



### Ferrari guarantees:



PROJECT

The design criteria have the support of very modern programs that work in 3D.



CHECK

All the components of our machines are tested before going into production. This guarantees the quality and reliability of our products.



COMFORT

Designing for comfort is one of the essential components of our technical staff's Mission.



SPARE PARTS

Tested and guaranteed original spare parts.  
E-parts is the on-line support for fast and easy service.



ASSISTANCE

Efficient and valid assistance service with the support of friendly and competent technical staff: E-service is the on-line tool supporting the service.



SALES FORCE

An extensive and efficient sales force guaranteeing service and assistance.

You can pay a visit to your local Ferrari dealer or visit our website [www.ferrariagri.it](http://www.ferrariagri.it) to discover which novelties are waiting for you.



The data in this leaflet are supplied indicatively: the models described may be modified, without notice, by the Manufacturer.