

**FERRARI**

**CROMO K60 AR/RS**





# MUCH MANY ADVANTAGES WITH CROMO K60

FERRARI



**REVERSIBLE DRIVING POSITION**  
optional on all models.



**OS-FRAME TRANSMISSION**  
in order to optimize mechanical efficiency and stability even on rough terrain.



**ELECTRONIC JOYSTICK**  
in order to optimize hydraulic system performance facilitating operator control.



**KUBOTA ENGINE**  
with direct injection and counter-rotating mass: low fuel consumption, excellent performance and reliable over a long time period.



**PERFECT WEIGHT DISTRIBUTION ON THE AXLES**  
in order to optimize efficiency, machine stability and traction during operation.

**'LOW NOISE' CABINS**  
comfortable and compact cabins with high visibility.



**EXCELLENT DRIVING CONDITIONS**  
with ergonomic controls placed to be easily found and activated by the operator.



**HYDRAULIC SYSTEM**  
high performance hydraulic system to adopt a great deal of hydraulically-fired equipments.



**PLANETARY GEARS**  
only machine from its category with planetary gears on both axles in order to ensure maximum power transmission and durability.



**SHORT WHEELBASE**  
in order to reduce turning radius so as to be able to move with maximum ease even in small spaces.



## Comfort, high performance for a captivating design - unique tractor

Achievement of maximum efficiency and convenience has represented the key point in the development and implementation of the new **Cromo K60**. Prestigious engine, high performing hydraulic system, extremely compact dimensions and maximum operator comfort, in addition to an attractive and simple design are the characteristics making the difference between a **Cromo K60** and a competitor corresponding tractor.

**Cromo K60** has a large availability of options, making it extremely versatile and presents itself as a useful tool for row crop operations, greenhouse and nursery work and green maintenance, to be performed during both summer and winter time.

In the above mentioned context, related to municipal services, it is important to highlight the exceptional maneuverability characteristics, the small size, the great comfort and low overall operation costs.



# VERSIONS

## CROMO K60 AR

Isodiametric tractors, monodirectional or reversible, with central articulation



The **Cromo K60 AR** are specialized tractors, born to be used in particularly narrow areas: row cultivations, vineyards, orchards, greenhouses and nurseries besides the Winter and Summer maintenance, like for Municipalities. They are particularly performing machines, thanks to the isodiametric wheels and the frame with central articulation, their best qualities: agility and maneuverability. The limited steering radius, the reversibility of the driving position (optional) and the constant adherence to the ground make the **Cromo K60 AR** multi-purposes and versatile machines, which can be used for a great variety of works under total control. In spite of the limited dimensions, the driving position is particularly comfortable with easily reachable controls also in the reversed position.

## CROMO K60 RS

Isodiametric tractors, monodirectional or reversible, with steering wheels



The **Cromo K60 RS** are multi-purpose specialized tractors, particularly performing in vineyards, orchards, nurseries cultivations and greens maintenance. The low hub and the all-wheel drive assure stability and adherence to the ground and allow the **Cromo K60 RS** to work both on flat and uneven, sloping grounds. The short pitch and the narrow track enhance the maneuverability qualities and allow to operate also in narrow spaces. The engine power together with the perfect weight distribution on the axles are features which enhance the value of the **Cromo K60 RS** and make them incomparable for any use. The reversible driving position (optional) allows to operate practically and rationally both with towed and front attachments and to work in the highest precision and comfort.

# ENGINE



## Kubota V2203: power, performance and savings

The **Cromo K60** are mounting a 4-cylinder, 2.2 liter Kubota engine developing 48 horsepower with a vigorous torque of 145 Nm corresponding to just 1700 rpm.

The V2203 engine with direct injection is provided with a counter-rotating mass now absolutely necessary for cantilever engine machine applications in order to avoid annoying vibrations and redundant noise inside the cabin.

The provided application has - as excellence - an optimal position on the driveshaft side. V2203 engine is also completely biodiesel compatible.



HIGH DRIVING COMFORT



LESS VIBRATIONS



LESS NOISE



REDUCTIONS OF EMISSIONS



REDUCTIONS OF CONSUMPTION



RELIABILITY AND PERFORMANCE

CROMO	Type	Power (kw/hp)	No. of cylinders	Displacement	Aspiration	Cooling
K60	V2203	35,2 / 48	4	2197	Natural	Water

# FRAME AND TRANSMISSION

## An absolutely unique context

The **Cromo K60** are provided with OS-Frame transmissions awarding lots of advantages:

➤➤➤ A unique transmission shaft through the central assy moves both the gearbox main clutch and the PTO independent clutch, while assuring the best mechanical output and the highest tractor maneuverability.

➤➤➤ It is a "monolithic" structure in a single cast iron casting. The joint in the middle of the machine lets the front axle oscillate up to 15° with respect to the rear axle, stabilizing the machines on steep terrain. This assures the highest stability and constant traction, as the four wheels are always stuck on the ground.

➤➤➤ This special structure of the transmission with cantilever engine allows a particular low gravity centre without actual ground contact, essential feature for the operations to which the tractor is destined.



The **distribution of the weights on the axles**, 40% on the rear and 60% on the front, is proved optimal once the rear lifting equipment is mounted.

The ideal balance of the machine while working assures stability, safety and traction.

The **4-wheel drive** allows absolute safety on every terrain, exploiting to the maximum the machine's designed towing and security outfits.

# GEARBOX AND AXLES



## Gearboxes with the best speed range

Aware of the fact that the field of specialized tractors includes a wide variety of applications, **Cromo K60** were manufactured with the new Synchro 24 speed shift (12 forward + 12 reverse) by more than 30 km/h for both driving directions, with synchronized inverter and helical profile gears.

Logical speed sequence, no overlaps throughout all ranges, always allows right gear selection for the tasks for which the tractor is intended to, enabling optimal machine utilization, fuel saving, minor mechanical component and engine wear, an overall high operating quality.

The "Long-life" clutch designed for **Cromo K60** is a multiple oil bath discs one. It does not require adjustment or maintenance. Modular and smoothly engaging clutch, mounted in the transmissions system to reduce engine overhang and consequently the tractor length.



## High quality axles

**Cromo K60** are equipped with planetary gear axles. The choice has been dictated by the need to reduce wheelbase increasing manoeuvrability as well as to extend tractor prestige and reliability.

Gear fundamental features, with respect to older cheap "cascade" gears used by the competition, identify themselves with virtually unlimited gear life and greater power transmission achieved by having three gears instead of only one cheaper model.

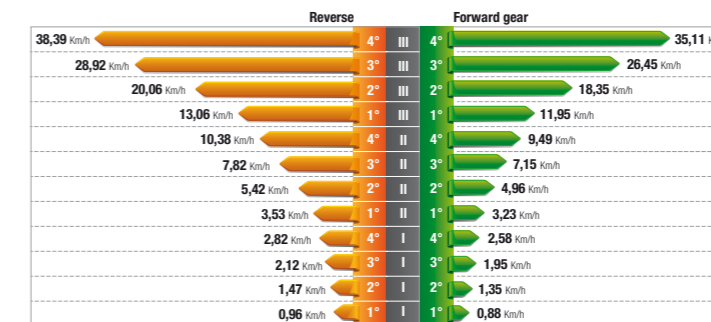

**Graph of the speeds in km/h - Engine speed: 2800 rpm**

The graph highlights the perfect progression of the ratios, without any speed overlapping between the ranges.



# HYDRAULIC SYSTEM

## High quality and performance

The hydraulic system is a dual circuit, powered by two gear pumps able to deliver:

	STANDARD	OVERSIZE PUMP (Optional   Standard with Joystick)
Flow rate to the lift and the distributors	22,1 lt/min	33,1 lt/min
Flow rate to the hydroguide and electro-hydraulic control	16,8 lt/min	22,1 lt/min



# REAR LIFT AND PTO



## Lever strength

Tractors such as **Cromo K60** are often used with performing equipment fitted on the lifting.

The solid rear hydraulic lift, with its high lifting capacity, relies on multi-purpose practical and versatile connections designed to adapt in a fast and simple way to all marketed equipments.

Lifting arms are equipped with normal connections, quick couplers and quick couplers with hook angular lateral adjustment.



Standard couplers



Quick couplings



L-shaped quick couplings

## Active and passive safety

The low hub, the constant traction and the efficiency of the braking system with multi-disc wet brakes assure the highest safety of operation in every conditions.

The differential lock, which can be operated by an ergonomically positioned knob on the instrument panel allows the tractor to be always in traction.

The roll-bar and the safety belts on the seat protect the operator from any possible capsizing.

## PLUS Everything close at hand

A specific **electronic control joystick** has been developed only for **Cromo K60**. The joystick can control both hydraulic system and rear rockshaft supplying 7 rear hydraulic connections and making practical and safe every manoeuvre involving tractor's hydraulics. The joystick control, placed as an arm rest on operator's right side is an integral part of the driver's seat. The seat and joystick rotate when reverse equipment mode is enabled. The joystick is designed to be vertically adjustable so the driver seat can be accessible from both right and left side. Despite machine's small size, joystick can even be set up within the cab.



In the oversize pump version, joystick option is a standard equipment and a heat exchanger is also provided in order to stabilize operating temperatures.

Operation hydraulic pressure is 180 bar.

Tractors without joystick are equipped with up to 6 hydraulic outlets located in the rear part of the equipment. This enables the use of equipment requiring large hydraulic flow. Lifting and devices controls are conveniently placed in an ergonomic position allowing intuitive manual operations.

## PTO with maximum power needed to transmission

The rear PTO is independent from the gearbox and synchronized with all progress speeds, essential for traction towing.

PTO can be engaged in a practical and safe way through an electro-hydraulic servo command.

Two speed regimes are available: 540 and 750 rpm.

PTO is always engaged under load, the brake in off position and security prevents accidental engagements.





# DRIVING POSITION



## Reserved to the driver

The driving location combines comfort, ergonomics, functionality and safety in an absolute original way.

The driving position is custom-fitted on the driver: the whole platform has been built with highest quality materials in order to obtain finishes resistant to atmospheric agents and to make the job more pleasant to the operator.

In the reversible version the driving module is mounted on silent-block absorbing vibrations and noise for a better comfort.

From the sprung seat the operator enjoys a complete view both on the machine and on the attachments.

The digital display is integrated in the instrument panel with its non-glare screen which guarantees the total control of the unit.

**PLUS**

## Reversible driving position: versatility and highest operation comfort

A few seconds are required to rotate by 180° the seat, the steering wheel and the console so that the operator may work having the equipment in front of him and constantly be able to control the operations.

This means: maximum security and comfort.



# CERTIFIED CABS

**FERRARI**



Available in Lusso and Comfort versions, **Cromo K60** cabs have been designed with the greatest care to even the smallest details to guarantee the inside comfort and not to damage the environment.

The structure is mounted on a suspended platform completely independent from the tractor structure in order to reduce noise and vibrations.

They are equipped with large, roomy and soundproof interiors. The large windows improve the driver's view when operating in traditional or even reversed driving position.

Air conditioning and heating are granted by a reliable, high performance system.



# Technical features\_ CROMO K60 AR



	8.25-16	250/80-18	280/70R18	320/65R18	260/70R20	31x15.50-15 XTC	31x15.50-15 STG	31x13.50-15 Garden
	WITH ADJUSTABLE RIM	WITH ADJUSTABLE RIM	WITH ADJUSTABLE RIM	WITH ADJUSTABLE RIM	WITH ADJUSTABLE RIM	WITH FIXED RIM	WITH FIXED RIM	WITH FIXED RIM
<b>A</b> Tyre width mm.	212	240	282	319	258	368	394	351
<b>B</b> Tyre height mm.	848	879	849	873	872	800	800	782
<b>C</b> Wheel track min/max mm.	<b>Mono</b>	794 - 1100	865 - 1107	869 - 1119	931 - 1119	1003	1003	1037
	<b>Rev</b>	827 - 1100	865 - 1107	931 - 1119	931 - 1119			
<b>D</b> Width min/max mm.	<b>Mono</b>	1006 - 1312	1105 - 1347	1151 - 1401	1250 - 1438	1371	1397	1388
	<b>Rev</b>	1039 - 1312	1105 - 1347	1213 - 1401	1250 - 1438			

TRACTOR DIMENSIONS CROMO K60 AR (mm):

	E	F	G	H	I Min-Max	L Max	M	N Max	O to the roof
<b>CROMO K60 AR</b>	1150	1390	730	3270	207/266	2220	675	2106	958

STEERING RADIUS CROMO K60 AR WITH THE FORESEEN WHEELS:

Tyre type	8.25-16	250/80-18	280/70 R18	320/65 R18	260/70 R20	31x15.50-15	31x13.50-15
mm	2450	2500	2530	2650	2600	2700	2700

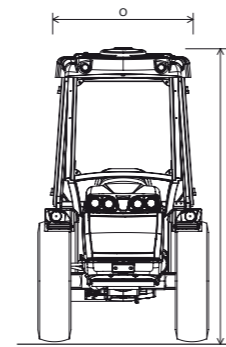
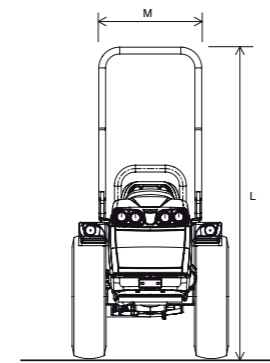
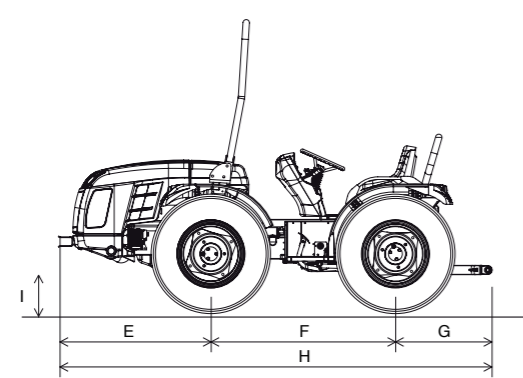
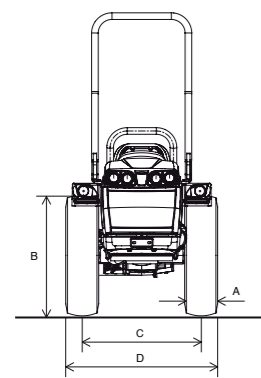

	CROMO K60 AR
<b>CHASSIS</b>	Swinging integral chassis OS-FRAME with central articulation
<b>ENGINE</b>	4-cycle Diesel engine with direct injection
Manufacturer	KUBOTA
Model	V 2203 M-DI
Number of cylinders	4
Displacement cm <sup>3</sup>	2197
Aspiration	Naturally aspirated
Emission level	Tier 3
Balancing	With counter-rotating balancing weights
Power KW/HP	35,2 / 48
Nominal speed (rpm)	2800
Maximum torque (Nm/rpm)	144,6 / 1700
Cooling	Water
Tank capacity (lt.)	45
<b>TRANSMISSION</b>	Synchronized gearbox: 24 speeds (12 forward and 12 reverse) with synchronized reverser
Main clutch	Multidisc, in oil bath
<b>DIFFERENTIAL</b>	Front and rear with simultaneous differential lock and electro-hydraulic control
<b>AXLES</b>	Front and rear, with epicyclic reduction units
<b>DRIVE</b>	Four-wheel drive, permanent
<b>POWER TAKE-OFF</b>	Rear, independent from the gearbox, 540/750 r.p.m. and synchronized with the gearbox. Engageable under load with brake in disengaged position
PTO clutch	Multidisc, in oil bath
Engagement control	Electro-hydraulic
<b>HYDRAULIC SYSTEM</b>	Double circuit with independent pumps
Flow rate to the lift and the distributors (l/min.)	22,1 (optional oversize pump 33,1 l)
Flow rate to hydraulic pump which controls the hydroguide and electro-hydraulic control (l/min.)	16,8 (optional oversize pump 22,1 lt and heat exchanger)
Maximum hydraulic pressure (bar)	180
<b>DISTRIBUTORS</b>	Mechanical control to max. 8 hydraulic couplers
Rear (standard)	1 double acting (Hydraulic lift by rams) 2 double acting (Draft and position control)
Rear (optional)	1 single acting and 1 double acting with float or 2 double acting (Hydraulic lift by rams) 1 single acting and 1 double acting with float instead of the serial ones (Draft and position control)
Joystick (optional)	Electronic control of distributors composed of: 1 single-acting with adjustable flow, free return and 3 double-acting
<b>ELECTRIC SYSTEM</b>	
Battery (Ah)	70
Alternator (A)	70
<b>REAR LIFT</b>	Standard: by two external rams - Optional: draft and position control
Three-point hitches	Standard: standard couplers cat. 1 - Optional: quick couplings cat. 1, L-shaped lift arms, lift rods adjustable in length and hooks adjustable in width
Three-point tie bar	With manual adjustment
Lifting capacity at the end of the arms kg	1510
<b>DRIVING UNIT</b>	With half-platform for the monodirectional version - With suspended platform on "silent-block" for the reversible version
Driving platform	Monodirectional or reversible with rotating platform and twin pedal assembly
<b>SEATS</b>	Standard: sprung seat - Optional: 'Bostrom' seat
<b>SERVICE BRAKES</b>	Oil immersed multidisc, acting on the rear transmission, with mechanical control
Parking brake	Acting on the service brakes
<b>STEERING</b>	With hydrostatic steering by two rams, acting on the central articulation. Flow deviator for steering unit for the reversible version
<b>SAFETY</b>	
Roll-bar frame (standard)	Front, homologated
Cabin (optional)	Sound-proof, mounted on 'Silent block', heating and ventilation systems. Optional: air conditioning
<b>CONSOLE</b>	
Digital type	With chrono-tacho-gyrometer, water thermometer, control warning lights and acoustic alarm. Reading of rpm, forward speed and rotation speed of power takeoff
<b>TYRES</b>	
Standard	8.25-16
Optional	250/80-18 * 280/70R18 * 320/65R18 * 260/70-20 * 31x15.50-15 XTC and STG * 31x13.50-15 Garden
<b>TOW HOOKS</b>	
Standard	Rear CUNA and front
Optional	Rear rotating or rear adjustable in height (Slider type) tow hooks, both EC approved or CUNA rear adjustable in height (Slider type)
<b>WEIGHT OPERATIONAL</b>	
With roll-bar (kg)	1560
With cabin (kg)	1720
<b>OPTIONAL</b>	Flash light, front weight and weights for wheels



# Technical features \_ CROMO K60 RS



	8.25-16	250/80-18	280/70R18	320/65R18	260/70R20	31x15.50-15 XTC	31x15.50-15 STG	31x13.50-15 Garden
	WITH ADJUSTABLE RIM	WITH ADJUSTABLE RIM	WITH ADJUSTABLE RIM	WITH ADJUSTABLE RIM	WITH ADJUSTABLE RIM	WITH FIXED RIM	WITH FIXED RIM	CON CERCHIO FISSO
<b>A</b> Tyre width mm.	212	240	282	319	258	368	394	351
<b>B</b> Tyre height mm.	848	879	849	873	872	800	800	782
<b>C</b> Wheel track min/max mm.	999 - 1305	996 - 1312	984 - 1324	1074 - 1324	987 - 1325	1100 - 1208	1100 - 1208	1066 - 1242
<b>D</b> Width min/max mm.	1211 - 1517	1236 - 1552	1266 - 1606	1393 - 1643	1245 - 1583	1468 - 1576	1494 - 1602	1417 - 1593

TRACTOR DIMENSIONS CROMO K60 RS (mm):

	E	F	G	H	I Min-Max	L Max	M	N Max	O to the roof
<b>CROMO K60 RS</b>	1150	1390	730	3270	207/266	2220	675	2106	958

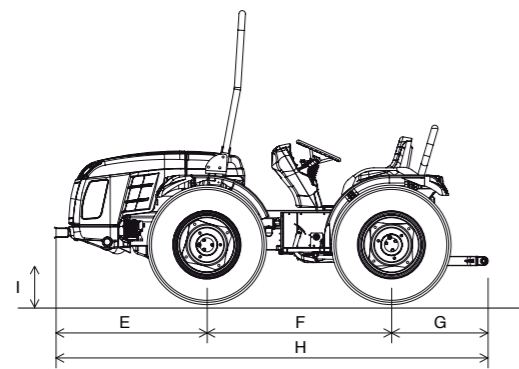
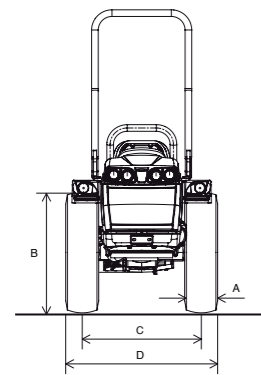

STEERING RADIUS CROMO K60 RS WITH THE FORESEEN WHEELS:

Tyre type	8.25-16	250/80-18	280/70 R18	320/65 R18	260/70 R20	31x15.50-15	31x13.50-15
mm	2800	2830	2930	2950	3350	3250	3200

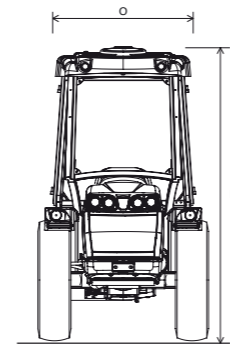
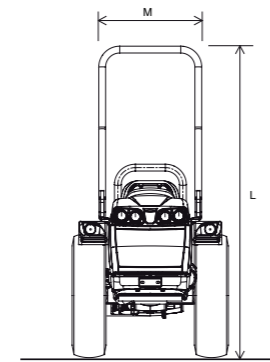

	CROMO K60 RS
<b>CHASSIS</b>	Swinging integral chassis OS-FRAME with steering wheels
<b>ENGINE</b>	4-cycle Diesel engine with direct injection
Manufacturer	KUBOTA
Model	V 2203 M-DI
Number of cylinders	4
Displacement cm <sup>3</sup>	2197
Aspiration	Naturally aspirated
Emission level	Tier 3
Balancing	With counter-rotating balancing weights
Power KW/HP	35,2 / 48
Nominal speed (rpm)	2800
Maximum tractor torque (Nm/rpm)	144,6 / 1700
Cooling	Water
Tank capacity (lt.)	45
<b>TRANSMISSION</b>	Synchronized gearbox: 24 speeds (12 forward and 12 reverse) with synchronized reverser
Main clutch	Multidisc, in oil bath
<b>DIFFERENTIAL</b>	Front and rear with simultaneous differential lock and electro-hydraulic control
<b>AXLES</b>	Front and rear, with epicyclic reduction units
<b>DRIVE</b>	Four-wheel drive, permanent
<b>POWER TAKE-OFF</b>	Rear, independent from the gearbox, 540/750 r.p.m. and synchronized with the gearbox. Engageable under load with brake in disengaged position
PTO clutch	Multidisc, in oil bath
Engagement control	Electro-hydraulic
<b>HYDRAULIC SYSTEM</b>	Double circuit with independent pumps
Flow rate to the lift and the distributors (l/min.)	22,1 (optional oversize pump 33,1 l)
Flow rate to hydraulic pump which controls the hydroguide and electro-hydraulic control (l/min.)	16,8 (optional oversize pump 22,1 lt and heat exchanger)
Maximum hydraulic pressure (bar)	180
<b>DISTRIBUTORS</b>	Mechanical control to max. 8 hydraulic couplers
Rear (standard)	1 double acting (Hydraulic lift by rams) 2 double acting (Draft and position control)
Rear (optional)	1 single acting and 1 double acting with float or 2 double acting (Hydraulic lift by rams) 1 single acting and 1 double acting with float instead of the serial ones (Draft and position control)
Joystick (optional)	Electronic control of distributors composed of: 1 single-acting with adjustable flow, free return and 3 double-acting
<b>ELECTRIC SYSTEM</b>	
Battery (Ah)	70
Alternator (A)	70
<b>REAR LIFT</b>	Standard: by two external rams - Optional: draft and position control
Three-point hitches	Standard: standard couplers cat. 1 - Optional: quick couplings cat. 1 or quick couplings cat. 1, L-shaped lift arms, lift rods adjustable in length and hooks adjustable in width
Three-point tie bar	With manual adjustment
Lifting capacity at the end of the arms kg	1510
<b>DRIVING UNIT</b>	With half-platform for the monodirectional version - With suspended platform on "silent-block" for the reversible version
Driving platform	Monodirectional or reversible with rotating platform and twin pedal assembly
<b>SEATS</b>	Standard: sprung seat - Optional: 'Bostrom' seat
<b>SERVICE BRAKES</b>	Oil immersed multidisc, acting on the rear transmission, with mechanical control
Parking brake	Acting on the service brakes
<b>STEERING</b>	With hydrostatic steering, acting on the front wheels. Flow deviator for steering unit for the reversible version
<b>SAFETY</b>	
Roll-bar frame (standard)	Front, homologated
Cabin (optional)	Sound-proof, mounted on 'Silent block', heating and ventilation systems. Optional: air conditioning
<b>CONSOLE</b>	
Digital type	With chrono-tacho-gyrometer, water thermometer, control warning lights and acoustic alarm. Reading of rpm, forward speed and rotation speed of power takeoff
<b>TYRES</b>	
Standard	8.25-16
Optional	250/80-18 * 280/70R18 * 320/65R18 * 260/70-20 * 31x15.50-15 XTC and STG * 31x13.50-15 Garden
<b>TOW HOOKS</b>	
Standard	Rear CUNA and front
Optional	Rear rotating or rear adjustable in height (Slider type) tow hooks, both EC approved or CUNA rear adjustable in height (Slider type)
<b>WEIGHT OPERATIONAL</b>	
With roll-bar (kg)	1580
With cabin (kg)	1720
<b>OPTIONAL</b>	Accumulator for weight compensation HDR with Dual Floating System (only for reversible version), Flash light, front weight and weights for wheels



## THE SERVICES



### SPARE PARTS

A complete range of original spare parts, guaranteed directly by the manufacturer.



### ASSISTANCE

A team of specialists, well prepared and available to assure an efficient and resolving service.



### WARRANTY

A precise certainty for the customer's satisfaction:  
2-year warranty included in the price.



### LUBRICANTS

Ferrari recommends to use the original PowerLube lubricants.



M A D E I N I T A L Y



### BCS S.p.A.

Viale Mazzini, 161 - 20081 Abbiategrasso (Milano)  
Tel. +39 02 94821 - Fax +39 02 94960800 - info@bcs-ferrari.it

[www.ferrariagri.it](http://www.ferrariagri.it)