

BRODD EUROPA[®]

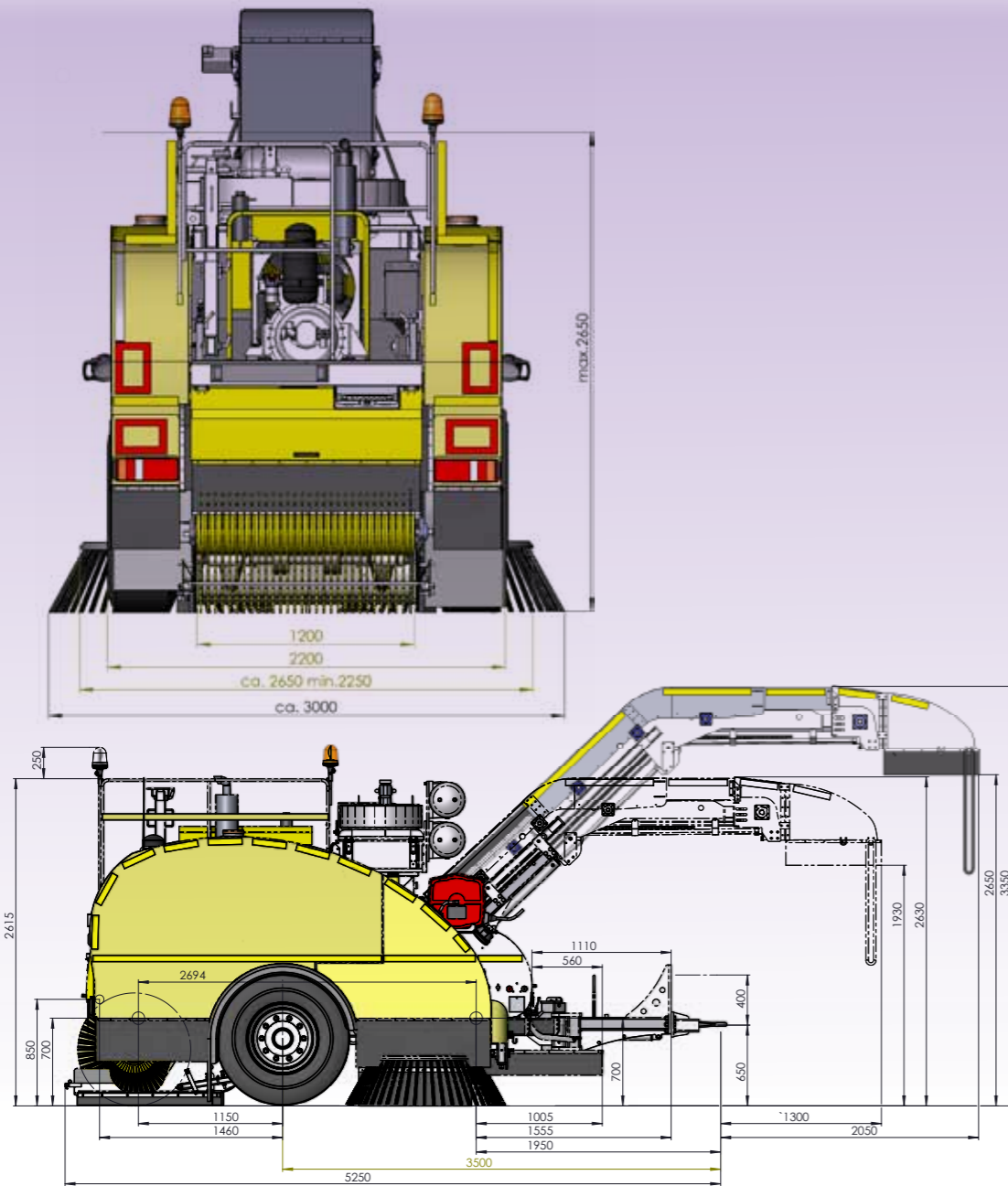

BRODD group



BRODD SWEDEN AB
Sjögatan 27
SE-591 30 MOTALA

Telephone
+46 141 20 89 00 info@broddsweden.com www.broddsweden.com

Europa 2 06/09/2015 CH



Heavy duty sweeper
with 80 km/h transport speed

Sweeping capacity up to 1,2 ton per minute!

BRODD EUROPA[®]

The heavy duty, high transport sweeper

Simple, sturdy and silent

The elevator principle

Both side brushes (4) sweep the dirt into the middle of the sweeper, the wide roller brush (1) throws the debris up into the feeding screw (2) further up to the elevator (3) equipped with easy replaceable rubber rakes - and the conveyor belt (5) transports it up to the platform body of the truck. The suction system (option) (6) prevents the dust and it gets **clean - faster and even more efficient!**

- The simple and reliable sweeping principle -

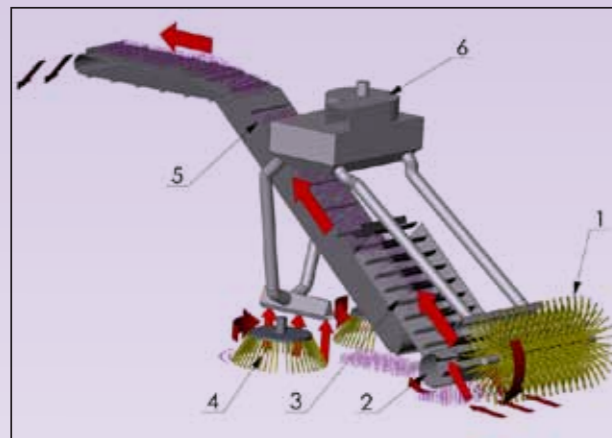

1. Roller brush
2. Feeding worm
3. Elevator
4. Side brush
5. Conveyor belt
6. Suction system (option)



"BRODD float" brush suspensions

The side brushes as well as the roller brush adjust automatically the correct pressure to the road surface. Due to the unique "BRODD float" system no manual adjustments of the brush suspension must ever be done.

Sprinkler system

The hydraulically driven membrane pump with capacity of maximum 26 l/min forms a water screen in front and around the side brushes. Another ramp is located in front of the roller brush and effectively prevents from dust.



Powerful engine

The sweeper is powered with a diesel engine. (Step 3 certified). Equipped with oil cooler as well as oil bath air filter to facilitate powerful and trouble free operation.



Simple maintenance

The heart of the sweeper, the electrical and hydraulic valve system is built into a locker, well protected from dust, wetness and damage.

Fashioned hydraulic system

EUROPA is equipped with a reliable and advanced hydraulic system.

All operations are easily accessible from the centrally located control unit.



Weed brush unit (option)

For fluffing and to remove hard, compacted sand and weed from the street and the kerb an additional weed brush is available as option. It is electrically controlled from the driver's cab.



Suction system (option)

for collection of fine dust at the roller brush and side brushes. Prepared for the PM10 standard.



Remote control

Easy comfortable remote control unit from the driver's cab with the following functions:

- Light in the on/off buttons
- Engine start/stop
- Sweeping on/off
- Water pump on/off
- Individual speed control of the conveyor belt for full loading on the platform body of the truck
- Beacon lights on/off
- Conveyor up/down
- Side displacement of the draw bar
- Adjusting of tilting angle right side brush
- Breaking up attachment up/down (option)
- Suction unit on/off (option)

Third side brush (option)

for extension of sweeping width, right side

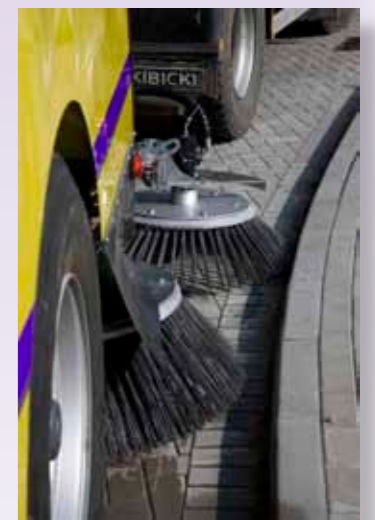

Height regulation of the conveyor

Hydraulically regulation allows You to adapt the sweeper to different truck heights.