

All Rights Reserved

Materials and specifications are subject to change without notice.
Featured machines in photos may include additional equipment. See your XCMG dealer for available options.



Mini Excavators
XE27E



XCMG European Sales and Services GmbH

Address: Europark Fichtenhain B 4,47807 Krefeld, Deutschland
Tel: +49 (0) 2151 8206 890
Fax: +49 (0) 2151 8206 899
E-Mail: info@xcmg-ess.de

XUZHOU CONSTRUCTION MACHINERY GROUP IMP. & EXP. CO., LTD

Address: No.1, Tuolanshan Road, Xuzhou Economic Developing Zone, Jiangsu, China 221004
Tel: + 86(0) 516 8773 9703
Fax: + 86(0) 516 8773 9230
E-Mail: europe@xcmg.com

www.xcmg.com

Rated power: 15.4 kW
Operating weight: 2.78 t
Standard bucket capacity: 0.06 m³





INTRODUCTION OF XCMG

Founded in 1943, XCMG is a multinational corporation with the most comprehensive range of competitive, influential products in the construction machinery industry. Our business covers eight key areas: construction machinery, heavy trucks, mining machinery, sanitation machinery, machinery components, construction, finance, and the ICT industry.

XCMG has established a global R&D network with a total of six centers in China, the US, Germany, Brazil and India, with the China national technology center at its core. In addition to a number of manufacturing bases in China, the US, Germany, the Netherlands, Poland, Austria, Brazil, India, and Uzbekistan, we possess two complete machine brands (XCMG, Schwing), and several component brands including FT and AMCA. The strength of this global R&D network and the manufacturing operations made XCMG the industry leading global construction equipment manufacturer that it is today.

For more than 30 years, XCMG has been sowing the seeds of overseas development as the No. 1 exporter in China's construction machinery industry. Today, we have 42 branches and offices, 315 distributors, and 526 contractors in 188 countries and regions worldwide and we are still growing rapidly.

XCMG IN EUROPE

Since its foundation in 2012, XCMG is gradually establishing a complete network including: R&D department, local distribution, supply chain management and an integrated customer services and training center. Nowadays, with 3 branches, XCMG has over 100 multinational employees in Europe, of which more than 50 % are R&D engineers:

ERC: XCMG European Research Center GmbH

EPC: XCMG European Purchasing Center GmbH

ESS: XCMG European Sales and Services GmbH

Our local professional R&D team and our cutting-edge innovation platform guarantee that our products are carefully crafted to the smallest detail according to the diverse needs of European customers.





High Performance from a Compact Size

► A Superior Model with Passionate Design

Developed with the concept of "Safe, Reliable, Efficient, and Comfortable", the XE27E hydraulic excavator offers additional value to the operator. New features are introduced, making the machines more productive, versatile, and cost effective.

- The Kubota Stage V D1105 engine, along with our load-sensing hydraulic system, provides efficiency and fuel economy.
- This compact short-tail excavator is designed to perform a wide variety of tasks on the most challenging job sites. It does not matter whether it is in demolition, landscaping, earthmoving, or material handling. It gets the job done!
- Convenient accessible service points make maintenance easier and reduce your potential downtime.

Boom Swing

The boom swing function together with the zero tail swing allows you to work in very narrow areas. The left and right boom swing angle is respectively 75° and 55°, it makes the XE27E easy capable to realize complex tasks in difficult operation conditions like digging parallel to a wall in a narrow driveway.

Made for Easy Transportation

With a set of buckets, hammer, and a trailer, our XE27E weighs less than 3,5 tons. The easy accessible tie-down points make it easy to switch between your jobsites.



Complete Equipped with AUX1, AUX2, and Quick Coupler lines.

With the multiple programmable 2-way proportional auxiliary lines and quick-coupler piping the XE27E meets almost all of your attachment needs.

Boom, Arm Safety Valves and Blade Holding Valve as Standard

The XE27E is fitted as standard with a boom cylinder safety valve, an arm cylinder valve, and a dozer holding valve to dig and handle all your materials in a safe way.



Operational Comfort

► Large Operator Environment with Ergonomic Control Layout

The XE27E gives the operator a large comfortable space in which to work. The ergonomic control layout, travel levers with standard pedals, and adjustable wrist rests are engineered to reduce operator fatigue and increase productivity.

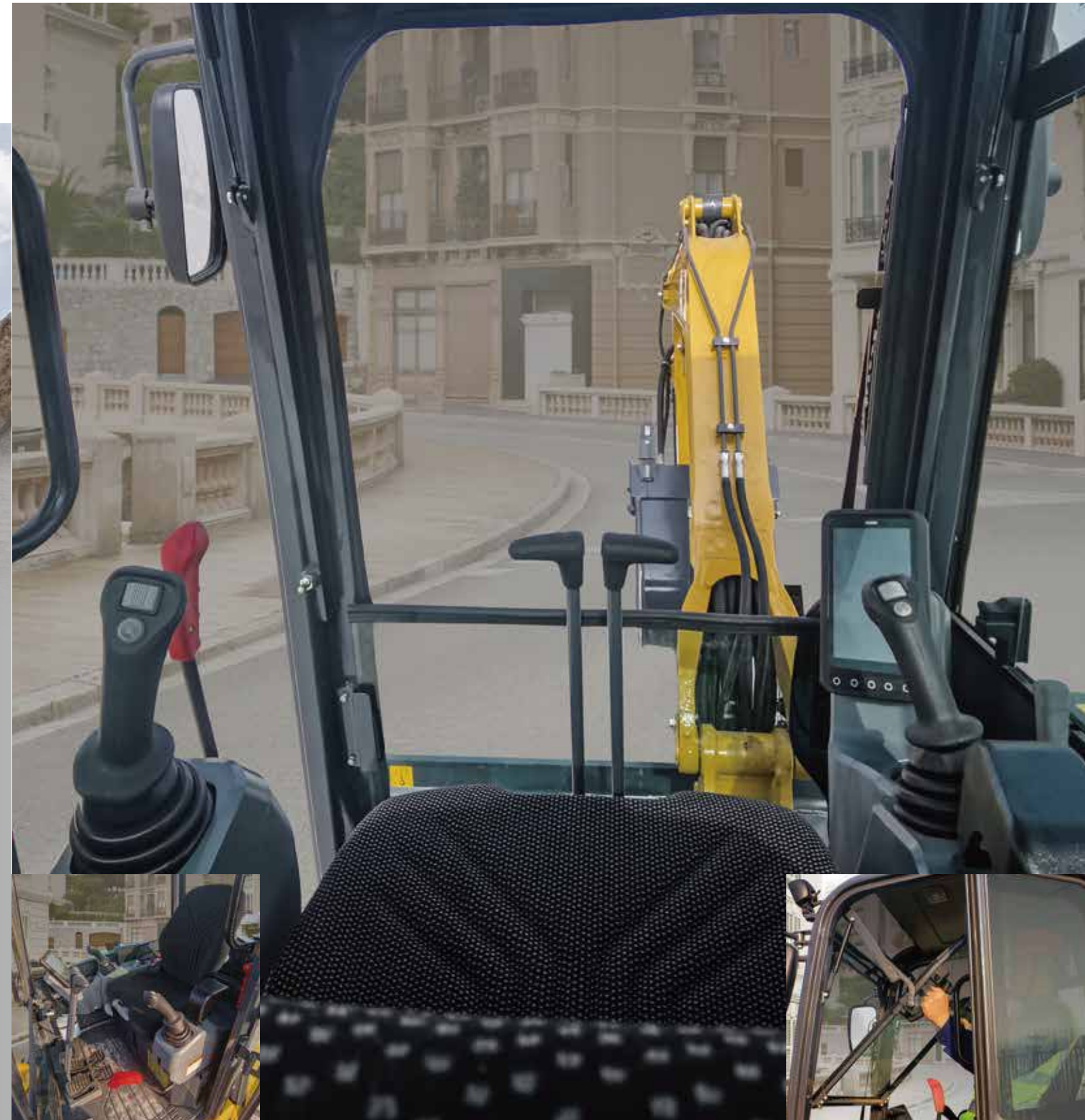

► Easy Service Access

The XE27E was developed with particular attention to ease of service access. With a single access point for the daily maintenance of all main components, fuel level gauge, and refueling through the lockable cap.



One-sided Engine Maintenance

The XE27E is designed for lower maintenance costs with longer service intervals - resulting in more machine availability on-site. Meanwhile, skilled XCMG-trained technicians are available to provide extra support when needed.



- ① Water separator
- ② Air cleaner
- ③ Engine oil filter
- ④ Fuel filter

■ Engine

	XE27E
Make/model	Kubota/D1105 /EU Stage V
Fuel/cooling	Diesel/Liquid,forced circulation
No. of cylinders	3
Piston displacement	1123 cm ³
Power output	15.4 kW (20.9 hp) / 2400 rpm (ISO 14396)
Max torque	70.3 N.m/1600 rpm
Bore x stroke	78.0×78.4 mm
Alternator	12 V/40 A

■ Hydraulic system

This original XCMG design allows independent and combined operations of all functions by hydraulic pilot controlled levers.

• Pump

	XE27E
Type	Load-sensing axial-piston pump with variable displacement
Maximum system flow rate	82.8 L/min
AUX1 & AUX2 maximum flow rate	25/7 L/min
AUX1/AUX2 standard relief pressure	180/180 bar

• Maximum system pressure

	XE27E
Boom	243 bar
Arm / bucket / travel	243bar/243 bar/190 bar
Swing	162 bar

■ Undercarriage

X-type undercarriage. The heavy-duty crawler chassis is very resilient with its fully welded, stress-free structure. Long service life is ensured by the use of first-class materials: hydraulic chain adjusters with shock-absorbing return springs, lifetime-lubricated track rollers, and idlers.

• Number of rollers and track shoes

	XE27E
Bottom rollers (per side)	3
Track shoes	Rubber
Overall track length	1980
Shoe width	300



■ Fluid capacities

	XE27E
Cooling system (radiator capacity)	6.5 L
Engine lubrication plus oil filter	5.1 L
Fuel tank	33 L
Hydraulic tank	22 L
Hydraulic system	40

■ Environment

Noise levels comply with environmental regulations (dynamic values).

• Noise emission

	XE27E
Noise level LpA (ISO 6396)	79 dB(A)
Noise level LwA (ISO 6395)	93 dB(A)

■ Swing mechanism

A high-torque, axial piston motor with a planetary reduction gear bathed in oil. The swing circle is a single-row, shear-type ball bearing with an induction-hardened internal gear. Internal gear and pinion gear are immersed in lubricant. Equipped with an automatic multi-disc slew brake.

• Swing system

	XE27E
Boom swing, left	75°
Boom swing, right	55°
Slew rate	10 rpm

■ Drive

Each track is driven by an independent, high-torque, axial piston motor through planetary reduction gears. Two control levers provide smooth travel upon demand.

• Speed & traction

	XE27E
Travel speed (low - high)	2-3.1 km/h
Traction force	29.7 kN
Gradeability	30°

■ Digging forces (ISO 6015)

	XE27E
Digging force, long arm (ISO 6015)	14 kN
Digging force, bucket (ISO 6015)	23 kN

■ Weight

	XE27E
Operating weight with canopy and bucket (ISO 6016)	2780 kg
Ground pressure with rubber tracks	26.4 kPa
Transport mass (no attachment)	2650 kg
Weight of steel tracks	200 kg
Weight of rubber tracks	134.5 kg

XE27E

With cab standard arm (1300 mm) without bucket

Lift Point Height	Over front blade up/down				Over Side				Max Radius (mm)		
	Lift At Max Radius (kg)	1.0 m	2.0 m	3.0 m	4.0 m	Lift At Max Radius (kg)	1.0 m	2.0 m		3.0 m	4.0 m
3 m	402			*435		290			360		3373
2 m	310			*479		220			350		3928
1 m	282		847	455	294	198		525	321	207	4105
Ground	290		791	430		203		525	298		3969
-1 m	350	*1229	794	425		244	*1229	527	294		3471
-2 m	*475		*596			465		562			2275

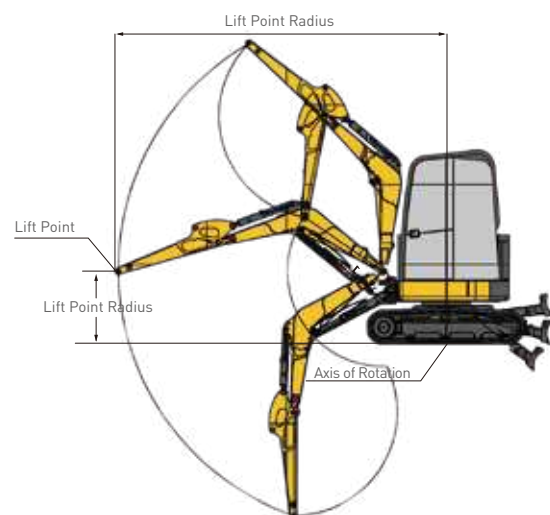

: Over front
 : Over side or 360°

1. The lifting capacity is based on the ISO10567 standard.
- 2.* = The maximum lifting capacity is limited by the hydraulic capacity of the machine.
3. The lifting capacity does not exceed 87 % of the hydraulic capacity or 75 % of the tipping load with the machine on level and firm ground.
4. The operator should be familiar with the machines operating- and maintenance manual. Local regulations concerning the safe operation of machinery must be followed at all times.
5. The lift diagrams only covers machines that are originally built by XCMG; without lifting chains and any other lifting equipment.
6. When the excavator is used to lift or handle materials, it must comply with local regulations.

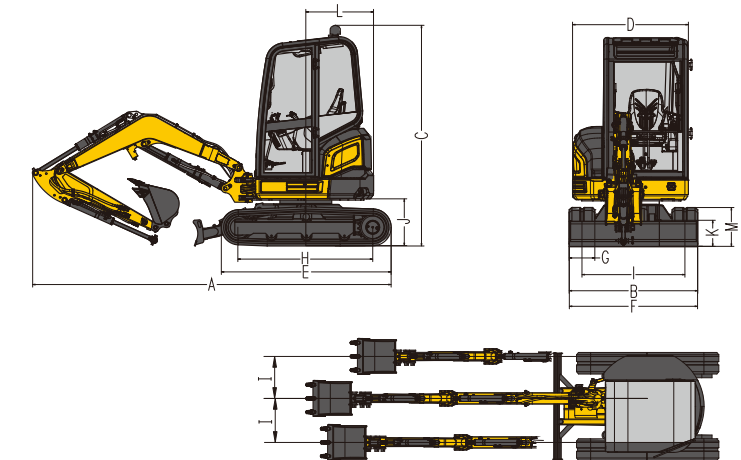
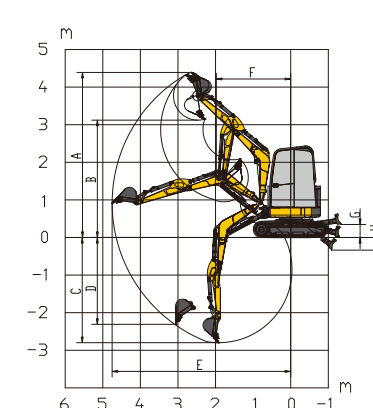

Working range

	XE27E	
A	Maximum digging height	4390 mm
B	Maximum dumping height	3120 mm
C	Maximum digging depth	2800 mm
D	Maximum vertical wall digging depth	2310 mm
E	Maximum digging radius	4750 mm
F	Minimum swing radius	1980 mm
G	Maximum dozer lifting height	300 mm
H	Maximum dozer cutting depth	330 mm
I	Boom deflection distance (left/right)	610/585 mm

Dimensions

	XE27E	
A	Overall length	4190 mm
B	Overall width	1500 mm
C	Overall height	2580 mm
D	Width of platform	1350 mm
E	Length of crawler	1980 mm
F	Width of chassis	1500 mm
G	Width of crawler	300 mm
H	Distance between tumbler	1560 mm
I	Track gauge	1200 mm
J	Counterweight clearance	535 mm
K	Minimum ground clearance	290 mm
L	Minimum tail swing radius	790 mm
M	Track height	457 mm

Standard and Optional Equipment

Engine

Kubota engine D1105, EU stage V

Hydraulic system

Single or dual way pipeline (AUX1)
 Dual way pipeline (AUX2)
 Hydraulic quick coupler pipeline
 Fingertip proportional control

Cab & interior

TOPS/ROPS (ISO 3471)
 OPG
 AM/FM radio with Bluetooth
 Adjustable seat
 DAB radio with Bluetooth
 Wear-resistant textile suspension seat with retractable belt
 Heater
 Color LCD monitor

Undercarriage

Fixed undercarriage
 Dozer blade
 Rubber tracks 300 mm
 Steel tracks 300 mm
 Track guards

Safety

Boom, arm, dozer cylinder safety valves
 Rotating beacon
 Engine overheat warning and restart prevention system
 Quick coupler switch with alarm
 Emergency stop switch
 Front cab protection
 LED work lights (2 on cab-front, 1 on boom)
 Tie down bracket for easy transport fixation

Other

Long arm 1300 mm
 General purpose bucket 0.061 m³ (600 mm)

Standard:
 Optional:
 -Some of this standard or optional equipment may not be available for certain markets.
 -Pictures may include attachments and optional equipment that are not available in your area.
 -Materials and specifications are subject to change without advance notice.
 -Please contact your local XCMG dealer for more information on availability or to customize your machine to suit your applications requirements.





XCMG-approved attachments



Genuine parts



Extension of warranty



Financial solutions



Maintenance contract



Telematics

Professional Integrated Complete Solutions

The XCMG group has built a strong reputation based on the quality, reliability and durability of its construction machinery. What's more, XCMG has gradually established a service network to constantly provide its local integrated and highly efficient complete solutions for all customers.

Full Range of Services Ready for you

In order to respond to your needs as fast as possible, XCMG experts are on their way to your job site from one of our facilities near you. A full range of services is available in order to reduce your total cost of ownership and increase your revenue.



XCMG Global Spare parts System



Mobile cranes



Excavators



Aerial work platforms



Wheel loaders



Road machinery

