



YANMAR

CARRIER

C12R-C



Operating weight	1100 kg
Payload	1150 kg
Engine Gross Power	7.7 kW

Robust performance for all terrains



COMPACTNESS

The C12R-C tracked carrier is perfect for jobsites where space is limited. With its compact overall dimensions, including a width of only 960mm, the C12R-C is at home on cramped worksites and can turn around within 1,810mm. A low centre of gravity combined with long crawlers means it is extremely stable and capable of ascending slopes of up to 30°.



EASE OF USE

The C12R-C is an operator's dream, with a smooth transmission and simple travel direction levers. To optimise movement around jobsites, the carrier has two travel speeds controlled by a single foot pedal – high speed for level ground (up to 5.5km/h) and low speed for difficult terrain and slopes.



DUMPING

The C12R-C is capable of carrying a 0.52m³ heaped load of up to 1,150kg. For ultimate versatility, the carrier's innovative dump vessel provides 3-way tipping and the opening side can be quickly switched with two easily removable pins. To ensure the vessel is completely emptied during unloading, the C12R-C can achieve dumping angles of 58° on the sides and 56° at the front.



ALL-TERRAIN ABILITY

The 230mm-wide rubber crawlers provide excellent weight distribution and manoeuvrability on soft or swampy ground, while preventing damage to asphalt and other surfaces. Track rollers with pendular supports in the undercarriage help the carrier cope with undulating surface conditions. Depending on the working surface, the crawler tension is easily changed by adjusting a bolt on each side.



MANAGEABLE MAINTENANCE

A large engine hood opening allows for quick access to important engine components for ease of maintenance. Routine checks and control points, like the water, engine oil, filters and fan belt are all positioned to facilitate easy access and servicing.



COMPACTNESS

The C12R-C is a heavy-duty machine with the flexibility of a garden implement. Despite its large carrying capacity of 1,150 kg, it comes with a total width of only 960 mm so that it can easily fit through standard openings of 1,000 mm. We have also ensured greater manoeuvrability with a length of just 2,650 mm and a small turning circle of 1,810 mm. The C12R-C is also extremely stable thanks to its low centre of gravity and ability to cope with slopes of up to 30°.



3-WAY DUMPING

The C12R-C improves efficiency on jobsites with fewer round trips when dumping waste and materials.

- + It enables work in the tightest spaces and comes with a large vessel capacity of 0.52 m³ heaped.
- + It tips three ways, so you can dump alongside a trench and use less space. You simply remove a pin (without tools) to change the position of the side opening.
- + It is a steep dumping angle of 58° on sides and 56° at the front for safe, fast and single unloading.



EFFICIENCY ON ALL TYPES OF TERRAIN

If you work in soft and swampy areas, you will appreciate the low ground pressure of the rubber crawlers and excellent weight distribution. The crawlers do not damage asphalt and provide great grip on soft ground, so that the C12R-C is an ideal alternative to a wheeled loader. Track rollers with pendular supports on the undercarriage offer a super smooth ride over uneven ground. Your body is protected from fatigue and you arrive home safely.



ENGINE

The C12R-C is equipped with an eco-friendly, EU Stage V compliant, water cooled, diesel engine with a gross power of 7.7 kW.

Thanks to its low noise level and excellent power to weight ratio, the C12R-C is the perfect carrier for urban and landscaping jobsites.



EASY MANOEUVRING

The C12R-C is a joy to manoeuvre thanks to its quick and safe reversible travel direction and an easily accessible transmission lever. The operator changes direction with one lever that precisely and safely alters the crawler rotation and chooses his travel speed with the speed select lever: high speed for flat and regular ground or low speed for tough terrain such as swamps or mud or on heavy slopes of up to 30°, where better traction is required.

ERGONOMIC PILOT SYSTEM

User experience is big with the C12R-C tracked carrier. Your comfort is at the heart of the experience:

- + Possibility to step in to the carrier from both sides.
- + Quick and easy start even harsh weather conditions.
- + Precise and intuitive control levers.
- + Hydrostatic transmission system that minimises vibration and ensures a comfortable ride.



ROBUSTNESS

We protect your investment by making our machines durable enough to last years. The C12R-C can work under extreme conditions, with a floor-plate thickness of 4.5 mm, gatepost thickness of 3.2 mm and robust gate levers. We also minimise wear while ensuring a smooth ride with rubber crawlers, which come with small metal inserts with a short pitch. While the crawlers are designed to last long a long time, they are elastic enough to take paved roads in their stride and can be adjusted easily with a simple bolt.



SAFETY

At Yanmar, we never forget people operate our machines, so safety is built-in naturally. The C12R-C is fitted with a ROPS structure to protect the operator against rolling over. Quickly foldable without using any tools, just by taking out the 2 pins, it offers a reduced height of only 1470 mm for transport. Safety features also include:

- + A safety bar on top of the vessel for operators working on steep slopes.
- + Wet multiple disk brakes for reliability and durability.
- + An alarm for reverse travel to keep your site colleagues safe and a safety system on the dumping lever to lock the vessel during travel.
- + Safety system on the dumping lever: locks the vessel during travel.
- + A support bar ensures perfect safety during maintenance operations.
- + Numerous anchor points for safe lifting and transportation.

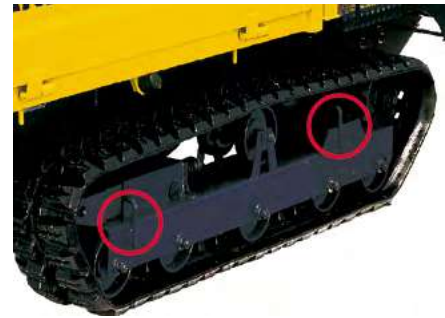

MAINTENANCE

You should always protect your investment with daily maintenance checks. With that in mind, we have made it easy to check your main engine components and water, oil and filter points. Simply lift the large engine-hood opening and everything is logically located and easy to maintain. You are efficient and safe on site.





SPECIFICATIONS

[DIMENSIONS]

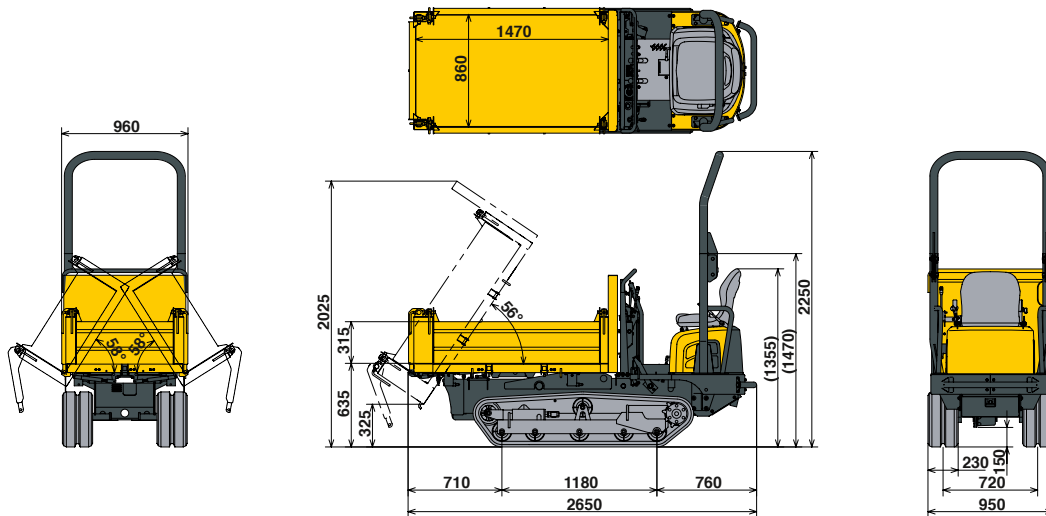

[WEIGHT +/- 2% (EN STANDARDS)]

	Weight	Ground Pressure
Operating weight	1100 kg	0,20 kgf/cm ²
Transport weight	1025 kg	0,19 kgf/cm ²
Payload	1150 kg	0,41 kgf/cm ²

[PERFORMANCE]

Max. travelling speed [High]	5,5 km/h
Gradeability	30°
Traction force	11,3 kN
Noise level (2000/14/CE & 2005/88/CE)	LW _a = 99 dBA LPA = 84 dBA

[DUMPING SYSTEM]

Dumping angle	58° (Side) / 56° (back)
Vessel dimensions (L x w x h)	1470 x 860 x 315 mm
Dumping mechanism	3-way
Dump vessel capacity (struck / heaped)	0,4 / 0,52 m ³
Dump clearance	325 mm

[UNDERCARRIAGE]

Track width	230 mm
Ground clearance	150 mm
Number of top rollers	1
Number of bottom rollers	5
Track tensioning system	Screw type
Min turning radius	1810 mm

[ENGINE]

Type	402J-05 IG84557R
Fuel	Diesel
Gross power	7,7 kW (at 2800 rpm)
Net power	7,5 kW (at 2800 rpm)
Displacement	0,507 l
Maximum torque at 2200 rpm	30,8 N.m
Cooling	Water cooling
Starter	12 V - 1, 2 kW
Battery	12 V - 36 Ah
Alternator	12 V - 14 A

[HYDRAULIC SYSTEM]

Maximum pressure	160 bar
Gear Pump (Dumping system)	11,5 l/min
Variable pump (Translation)	51,2 l/min

[CAPACITIES]

Fuel tank	230 mm
Hydraulic tank	150 mm
Hydraulic circuit	1
Engine Oil	5

MAINTENANCE FREQUENCY

[Change engine oil and filter: **50 hours (1st) / 500 hours (2nd)**] [Change fuel filter: **50 hours (1st) / 250 hours (2nd)**]
 [Change hydraulic oil filter: **50 hours (1st) / 500 hours (2nd)**] [Change hydraulic oil return filter: **50 hours (1st) / 1000 hours (2nd)**] [Change cooling fluid: **every 2000 hours**]



YANMAR



Yanmar Compact Equipment EMEA
25, rue de la Tambourine,
52100 SAINT-DIZIER France

ycee-contact@yanmar.com

www.yanmar.com

Printed in France - Materials and specifications are subject to change from the manufacturer without notice - Please contact your local Yanmar Compact Equipment EMEA dealer for further information.

GB_C12R-C_1120