



**YANMAR**

MINI EXCAVATOR

# Vi050-6B



Operating weight	4855 kg
Engine	4TNV88C-PBV with DPF
Digging force (arm)	22,7 kN
Digging force (bucket)	36,5 kN

# Reliability and robustness in a compact package



## COMPACTNESS

Yanmar, inventor of the ViO concept, has an unmatched experience in developing Zero Tail Swing excavators.



## NEW BOOM DESIGN

New design with a box structure in order to improve durability.



## POWERFUL YANMAR ENGINE

Well proven Yanmar 4TNV engines: 4-cylinder engine with direct injection and common rail system. This engine is also equipped with a cooled EGR and a DPF, which allow the machine to meet EU Stage V emission regulations. Auto deceleration and Eco-mode are available in standard.



## BEST COMPONENTS

Developed in Japan with renowned components for top quality. Design and performance of the components made for heavy-duty job sites and long service life.



## EASE OF MAINTENANCE

5 hoods or openings which allow easy access for components maintenance. Fast and easy daily checks or servicing.







## CABIN

Upgraded operator station: increased leg room, universal design, new electronic instrumentation, improved ergonomics and greatly improved noise level.



## EASY OPERATION

Control levers ideally located for exceptional movement precision. Proportional control of the auxiliary circuit. Standard equipment also includes an "auto-deceleration" feature, and an "eco-mode" to improve fuel consumption.



## HIGH PERFORMANCE

Upgrading of the powerline components (engine, hydraulic pump, control valve): no compromise between power and compactness. This will allow Yanmar customers to perform heavy-duty jobs in confined spaces.



## EXCELLENT STABILITY

Robust X-frame design of the undercarriage, increased operating weight and new boom design: impressive level of stability, especially on the side.



## WORKGROUP

New design of the workgroup, with changed cinematic and structure of the boom. Kingpost developed for better durability, longer service life and an improved TCO.



## UNMATCHED COMPACTNESS

The Vi050-6B is providing Yanmar customers with true peace of mind, especially in urban environment where space is limited.

The new design of the Vi050-6B boom also offers a very compact turning radius.

### ADVANTAGES OF THE VIO DESIGN

- + Improved safety for both the operator and the side workers: critical on the jobsites.
- + Rear blind spot reduced to a minimum: enhances again the safety for the workers around the machine.

### MACHINE HEIGHT

The redesign of the undercarriage contributes to reduce the machine height to an optimal 2,54 m, which facilitates transportation of the machine. It also improves the ground clearance to 345 mm.

## NEW BOOM DESIGN

The form of the boom has been radically changed, improving the lifting force of the Vi050-6B by 10 %. This new design also reduces the weight of the structure by 40 kg and increases the stability of the machine.

The box type structure of the boom enhances its durability and its service life. The base and the swing post of the boom have been strengthened, which improves its service life even more and reduces its Total Cost of Ownership.



### THE BEST BOOM AND ARM PROTECTION ON THE MARKET

The Vi050-6B benefits from a unique and complete protection of all its boom and arm cylinders. All cylinder tubes and rods are protected by a spring type steel plate, which reduces drastically the Total Cost of Ownership of the machine.





# COMFORT

## SPACIOUS AND COMFORTABLE CABIN

Putting the operator in the center of its design initiatives, Yanmar developed the “Universal Design” concept which is focused on ergonomics like door handle, handrails, door lock and hood handle. Combined to an increased leg room, it enables to improve the comfort and safety of the operator.

## IMPROVED AIR CIRCULATION

The air distribution and circulation in the cabin has been improved through the optimal location of six vents. The defrost function ensures perfect demisting of the cabin. These changes improve greatly the operator’s comfort, especially in hot weather conditions.



## ALL-AROUND VISIBILITY

The Vi050-6B design provides an ergonomic environment, excellent visibility and exceptional safety. The shape of the cabin provides the operator with an optimal 360° visibility in order to improve the safety on the jobsite and to make work more efficient. The Vi050-6B is equipped with three moving mirrors from his seat.

## SILENT CABIN

The Yanmar engineers have put a lot of emphasis on innovative ways to reduce the noise level. They succeeded in reducing the noise level by 3 dB(A). These changes impact the comfort level of the operator.

## COMFORTABLE ADJUSTABLE SEAT

The air suspension seat has numerous possibilities of adjustment to give the optimal seating position. The instrumentation panel has been redesigned as well as the armrests, which further enhance the operator’s comfort.



# PERFORMANCE

## VIPPS HYDRAULIC CIRCUIT

### (VIO PROGRESSIVE 3 PUMP SYSTEM)

The hydraulic circuit of the Vi050-6B has an aggregated power regulation equipped with two variable flow piston pumps and a multiple combination directional control valve:

- + Greater ease of use for the operator.
- + Increase the work speed.
- + Smooth and simultaneous performance of all the operations, even while traveling.

## POWERFUL YANMAR ENGINE

The Vi050-6B benefits from the most advanced technology of the leading manufacturer of industrial diesel engines. The 38,5 HP TNV engine is equipped with direct injection to create clean burning power. It has fully-electronic control to provide the Vi050-6B with total intelligent engine control. The engine is also equipped with a common rail system to allow fine-tuned electronic control of fuel injection.



## ELECTRICAL CONTROL SYSTEM EGR AND DPF

The Yanmar engine is fully compliant with EU Stage V requirement. This is achieved through two additional features.

The first is the cooled EGR (Exhaust Gas Recirculation) which reduces drastically the nitrogen oxides (NOx).

The second is the DPF (Diesel Particulate Filter) to clean up exhaust emissions (PM). Yanmar has successfully developed an exclusive regeneration system in order to combat clogging and cleaning down-time.

- + Drive motors shift automatically up and down depending upon the effort required. The operator is automatically provided with the best solution in terms of speed or pushing force, making operation easier and improving the operator comfort.
- + The Eco-Mode effectively controls the motor speed which is reduced by 300 rpm, thus allowing a very low fuel consumption.
- + The engine drops back to idle if the operator doesn't touch the operating levers for 4 seconds. Environmental performance (noise and emissions) and fuel consumption are even more improved.

## UNDERCARRIAGE AND STABILITY

The X-shaped box-section structure of the undercarriage provides excellent torsional stiffness. The frame is designed for maximum durability.

All the components of the undercarriage have been upgraded, which increases the durability and the service life of the machine and reduces its TCO.

This new undercarriage design and an optimized mass distribution contribute to improve the stability of the Vi050-6B.

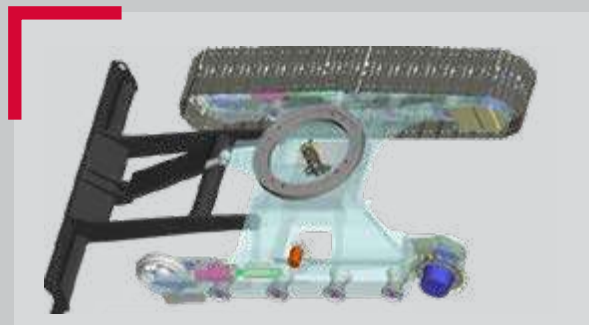

# SAFETY

The structure of the Vi050-6B cabin has been designed to meet the ROPS (Roll-Over Protective Structure) certification as well as the FOPS (Falling Object Protective Structure) level 1.

## LED LIGHTING: EFFICIENCY AND LOW CONSUMPTION

In order to work safely, efficiently and with accuracy in the darkness, the Vi050-6B is equipped in standard with 1 LED light positioned in the inner part of the boom. The LED technology provides a powerful light while reducing energy consumption which increases the service life of the battery. In option, two LED lights can be added at the front of the cabin as well as one LED rear light and a beacon.

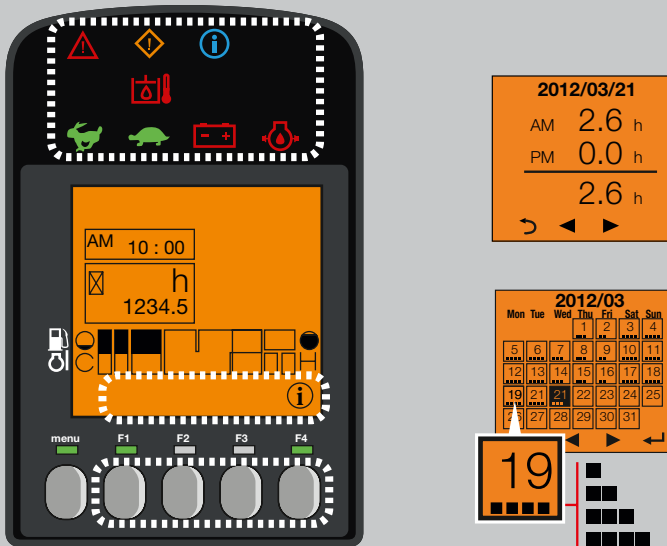

## DIGITAL INTERFACE

The Vi050-6B is equipped with a digital interface which informs the operator in real time about the status of his machine. Perfectly integrated into the right hand console, the 3.3" screen provides excellent visibility. The interface provides the customer with useful information through LED lamps, or indications about important elements like fuel consumption, fuel gauge, coolant temperature gauge, etc...

The interface assists the customer for maintenance intervals and to program such interventions. It also works as a diagnostic tool in case of malfunction by sending an error code and an information icon on the display.

# MAINTENANCE

## EASY ACCESS

Daily maintenance has to be performed easily. There is one easy to open engine bonnet and the right-hand side cover is mounted on one hinge to open easily. This gives an access to all major elements: air filter, A/C compressor, radiator, refueling pump, battery, fuel tank, hydraulic oil tank alternator, engine oil dipstick, water separator, coolant level, etc... A flat floor mat makes cleaning easier.

## LONG SERVICE INTERVALS

Yanmar excavators are designed for working and therefore we increase the service intervals.





# EQUIPMENT



## [ STANDARD EQUIPMENT ]

### PERFORMANCE

4TNV88C-PBV with DPF Yanmar diesel | Direct Injection | Engine Control Unit (ECU) | Eco-Mode | Auto-Deceleration System | VIPPS Hydraulic system (ViO Progressive 3 Pump System) | High flow auxiliary circuit with proportional control to arm end | Automatic 2nd speed | Filter on steering hydraulic circuit | External hydraulic oil gauge | 1 LED light integrated into the boom.

### COMFORT AND EASE OF USE

LCD interface | Adjustable and reclining seat with fabric covers, air suspension and headrest | Adjustable wrist support | Foot rests | Wide travel pedals | Windshield with 2 fully retractable parts | Sliding double right side window | Transparent upper front part | Wiper | Windshield washer | Automatic ceiling lamp | 1 x 12V outlet | Storage boxes | Secure document storage | Holder.

### SAFETY AND DURABILITY

Handrails | Safety lever | Seat belt with retractor | Evacuation hammer | Anchor points | 3 mirrors | Horn | Blade cylinder supply hose into two parts | Complete protection of the cylinders (boom, arm and blade) | Hoses protected by abrasion resistant sleeves | Lockable covers.

### MISCELLANEOUS

Fuel gauge | Toolbox | Toolkit | Grease pump.

## [ OPTIONAL EQUIPMENT ]

### EQUIPMENT AND PERFORMANCE

Steel crawlers | Pads for steel crawlers | Long arm (+250 mm) | Additional counterweight (+195 kg) | High flow auxiliary circuit adjustment with potentiometer | Low flow auxiliary circuit with adjustable proportional control by potentiometer | Line high pressure 165 bar for hydraulic quick coupler with piloted safety devices (double effect) | Hydraulic line for clamshell bucket | Quick couplers | Bio oil | 2 LED lights at the front of the cabin | 1 LED beacon | Kit 1 rear LED light + 1 beacon | Improved fuel filtration | ½ circuit.

### COMFORT AND EASE OF USE

Reversible air conditioning | Adjustable and reclining seat with skaï covers, air suspension and headrest | Seat Cover | Radio | Electric refueling pump | Central greasing.

### SECURITY AND DURABILITY

Safety valves for lifting + overload warning | FOPS 1 front protection | Anti-theft device (key/keyboard) | GPS Tracking | Translation alarm.

## [ ATTACHMENTS ]

Yanmar gives you the attachment that fit your needs and match the safety standards in force in your country: mechanical quick coupler, hydraulic quick coupler, ditching bucket, swinging bucket, backhoe bucket, hydraulic breaker...



# DIMENSIONS

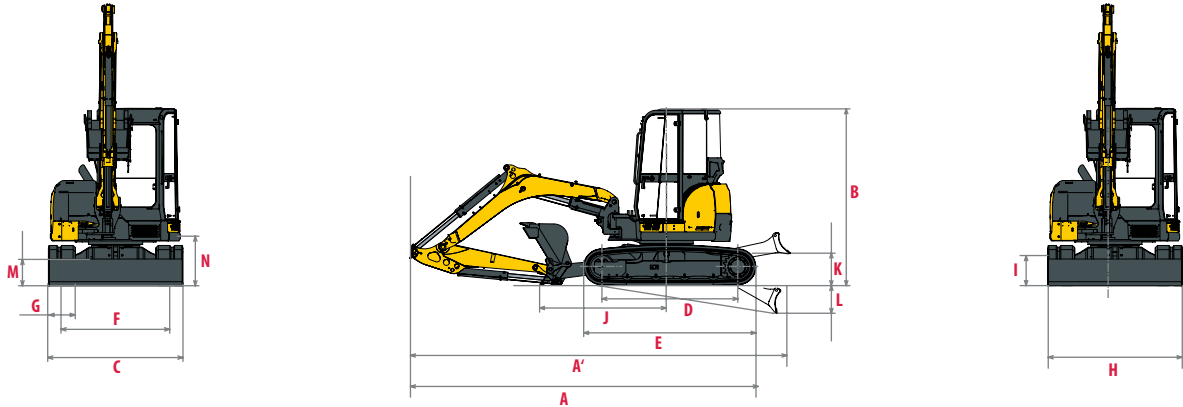

<b>A</b> Overall length	5230 / 5330 * mm	<b>H</b> Overall blade width	1970 mm
<b>A'</b> Overall length with blade at the back	5790 / 5890 * mm	<b>I</b> Overall blade height	400 mm
<b>B</b> Overall height	2540 mm	<b>J</b> Blade distance	1890 mm
<b>C</b> Overall width	1940 mm	<b>K</b> Max. lifting height above the ground	500 mm
<b>D</b> Length of track on ground	2070 mm	<b>L</b> Max. lowering depth from the ground	540 mm
<b>E</b> Undercarriage length	2590 mm	<b>M</b> Minimum ground clearance	345 mm
<b>F</b> Lane	1590 mm	<b>N</b> Ground clearance under counterweight	625 mm
<b>G</b> Track width	350 mm		

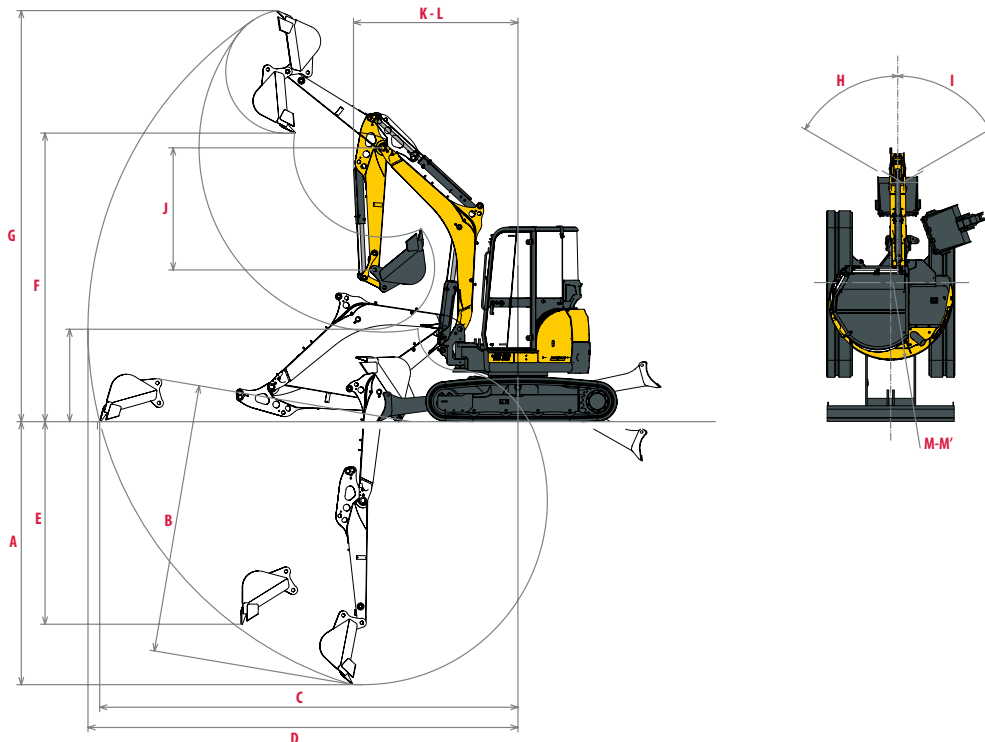

<b>A</b> Max. digging depth - Blade lifted	3360 / 3610 * mm	<b>H</b> Boom swinging base to left	68°
<b>B</b> Max. digging depth - Blade lowered	3540 / 3790 * mm	<b>I</b> Boom swinging base to right	68°
<b>C</b> Max. digging reach on ground	5540 / 5770 * mm	<b>J</b> Arm length	1450 / 1700 * mm
<b>D</b> Max. digging reach	5700 / 5920 * mm	<b>K</b> Front turning radius	2190 / 2360 * mm
<b>E</b> Max vertical wall	2690 / 2880 * mm	<b>L</b> Front turning radius with boom swing	1760 / 1910 mm
<b>F</b> Max. dumping height	3870 / 4000 * mm	<b>M</b> Rear turning radius	970 mm
<b>G</b> Max. cutting height	5530 / 5650 * mm	<b>M'</b> Rear turning radius with additional counterweight	1045 mm

\* With long arm



# SPECIFICATIONS

## [ WEIGHT +/- 2% (EN STANDARDS) ]

	Weight	Ground pressure
Operating weight (rubber tracks)	4 855 kg	0.31 kgf/cm <sup>2</sup>
Transport weight (rubber tracks)	4 780 kg	0.30 kgf/cm <sup>2</sup>
With steel tracks	4 985 kg	0.32 kgf/cm <sup>2</sup>
With additional counterweight	+ 195 kg	-

## [ ENGINE ]

Type	4TNV88C-PBV (Stage V engine with DPF)
Fuel	Diesel
Net Power	27.5 kW (at 2200 rpm)
Gross Power	28.3 kW (at 2200 rpm)
Displacement	2.189 l
Maximum torque	133.3 - 144.9 N.m
Cooling	Water cooling
Starter	12 V - 2.3 kW
Battery	12 V - 100 Ah
Alternator	12 V - 55 A

## [ HYDRAULIC SYSTEM ]

Maximum pressure	245 bar
1 double piston pump with variable flow	2 x 42.5 l.min <sup>-1</sup>
1 gear pump	37 l.min <sup>-1</sup>
1 gear pump for pilot line	10,8 l.min <sup>-1</sup>

PTO	Theoretical data at 2200 rpm	
	Pressure (bar)	Flow (l.min <sup>-1</sup> )
<b>2 way</b>	0 - 245	37 - 79,5
<b>1 way</b>	0 - 245	37 - 79,5



Oil flow decreases as the pressure increases

## [ PERFORMANCE ]

Travel speed	2.4 - 4.6 km/h
Rotation speed	10 rpm
Digging force (arm)	22.7 kN / 21.0 kN (with long arm)
Digging force (bucket)	36.5 kN
Traction force	42.7 kN
Gradability	30°
Noise level (2000/14/CE & 2005/88/CE)	79 dB(A) / 94 dB(A)

## [ UNDERCARRIAGE ]

Number of top rollers	1
Number of bottom rollers	4
Track tensioning system	Grease adjuster

## [ CAPACITIES ]

Fuel tank	66 l
Coolant	7.4 l
Engine oil	7.4 l
Hydraulic circuit	74 l
Hydraulic tank	38 l

## MAINTENANCE FREQUENCY

[ Change engine oil and filter: **50 hours (1<sup>st</sup>) / 500 hours (2<sup>nd</sup>)** ] [ Change fuel filter: **250 hours** ] [ Change hydraulic oil: **1000 hours** ]  
 [ Change hydraulic oil filter: **50 hours (1<sup>st</sup>) / 500 hours (2<sup>nd</sup>)** ] [ Change cooling fluid: **2000 hours** ] [ Cleaning particle filter : **3000 hours** ]  
 [ Change particle filter : **9000 hours** ]





**YANMAR**



Yanmar Compact Equipment Europe  
25, rue de la Tambourine,  
52100 SAINT-DIZIER France  
[ycee-contact@yanmar.com](mailto:ycee-contact@yanmar.com)  
[www.yanmarconstruction.eu](http://www.yanmarconstruction.eu)

Non contractual pictures - Printed in France - The manufacturer reserves the right to modify the information in this catalogue without notice. For further information, please contact your authorized Yanmar Compact Equipment dealer.

GB\_Vi050-6B\_0220